

SECTION A-A
SCALE 1:2

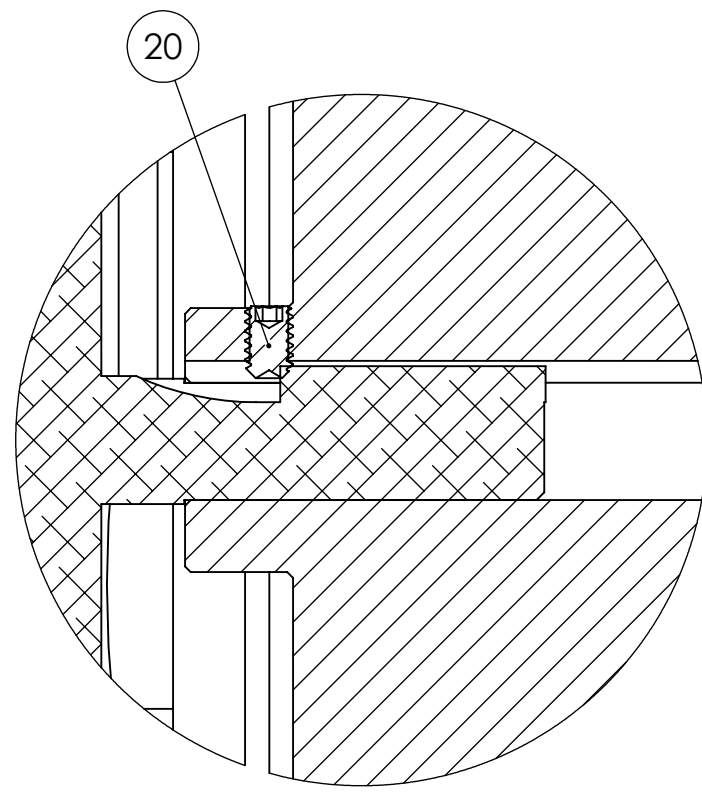

DETAIL C
DETAIL OF DRIVE PULLEY
SET-SCREW

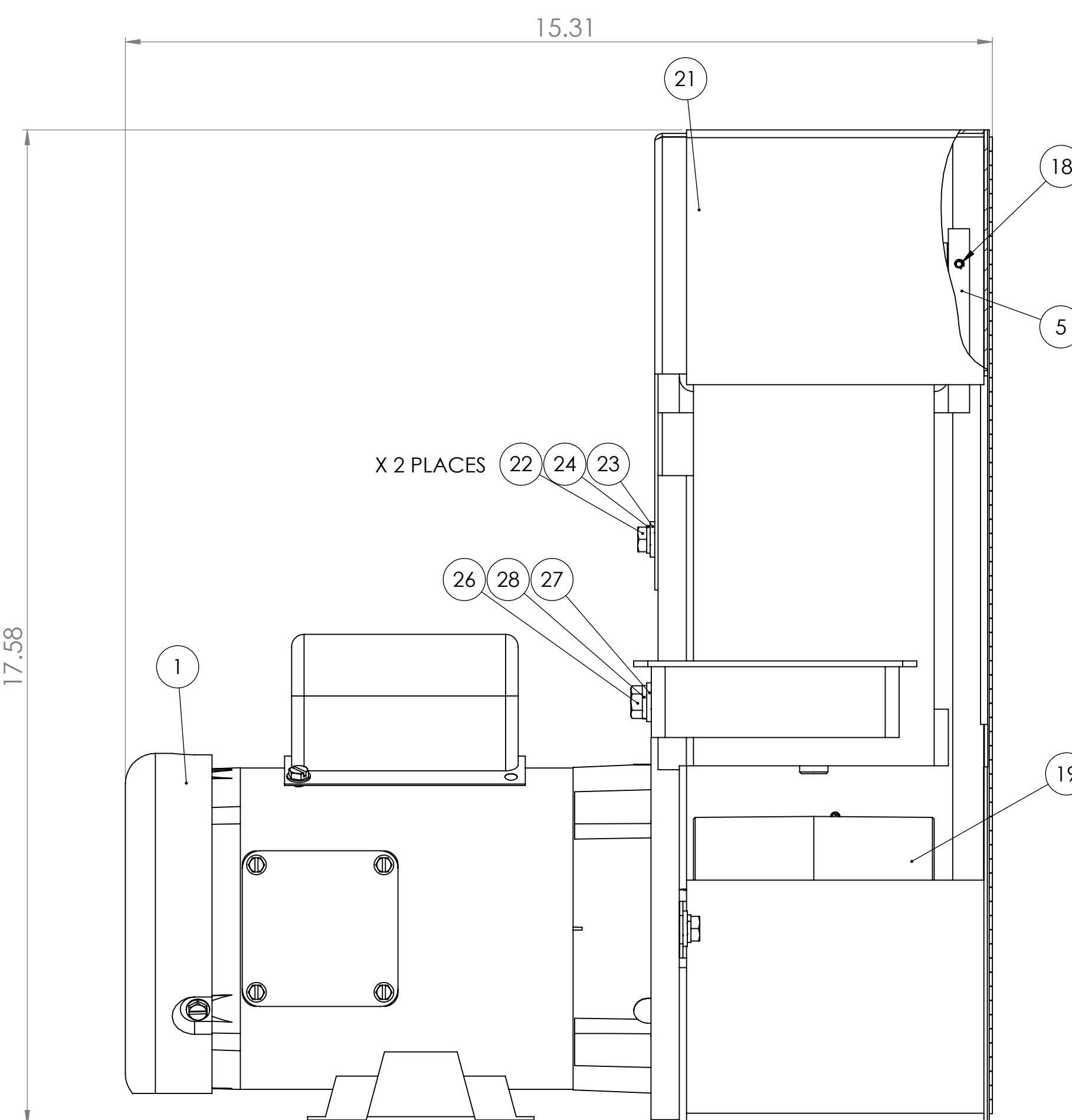
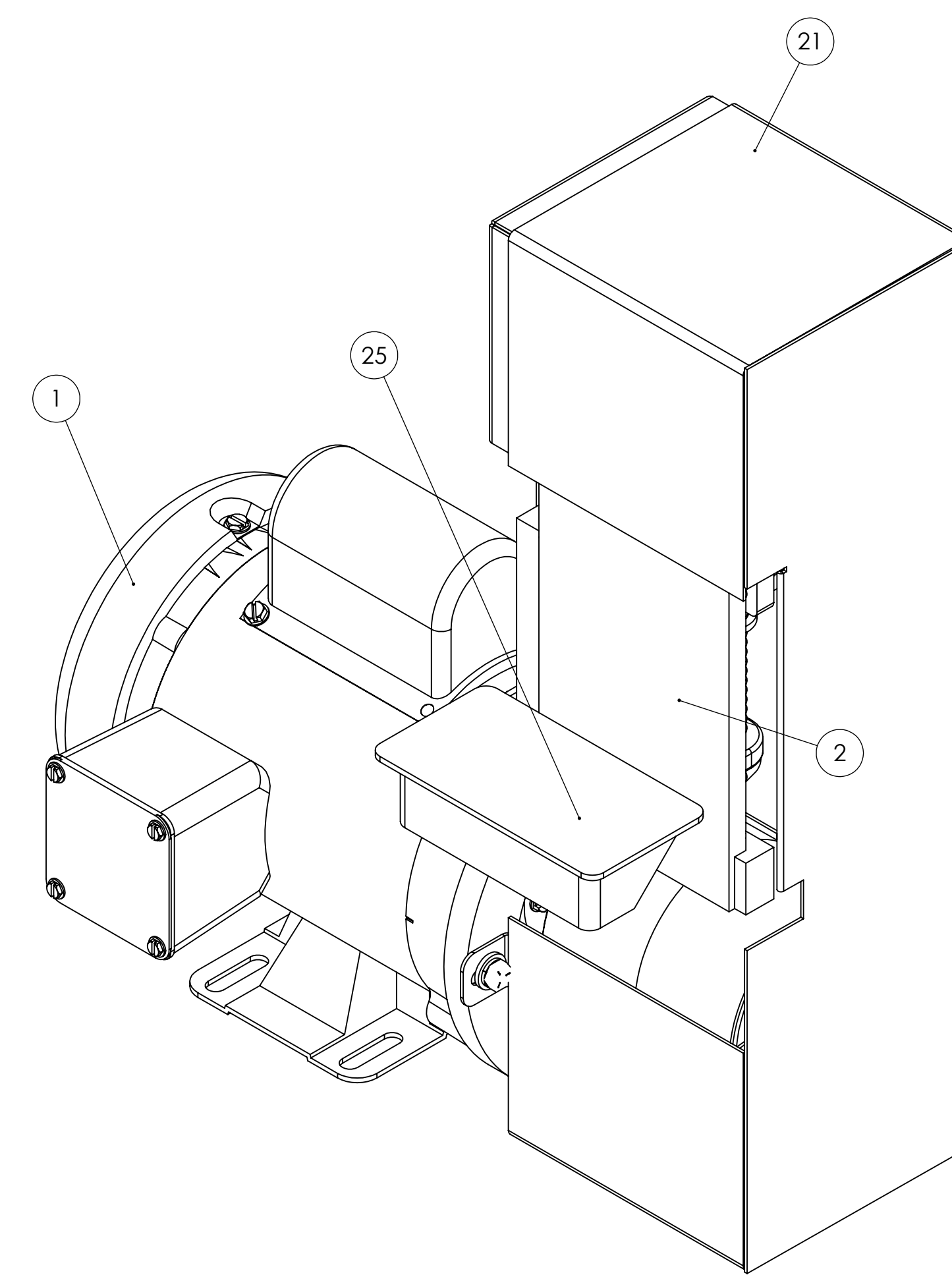

FRONT VIEW

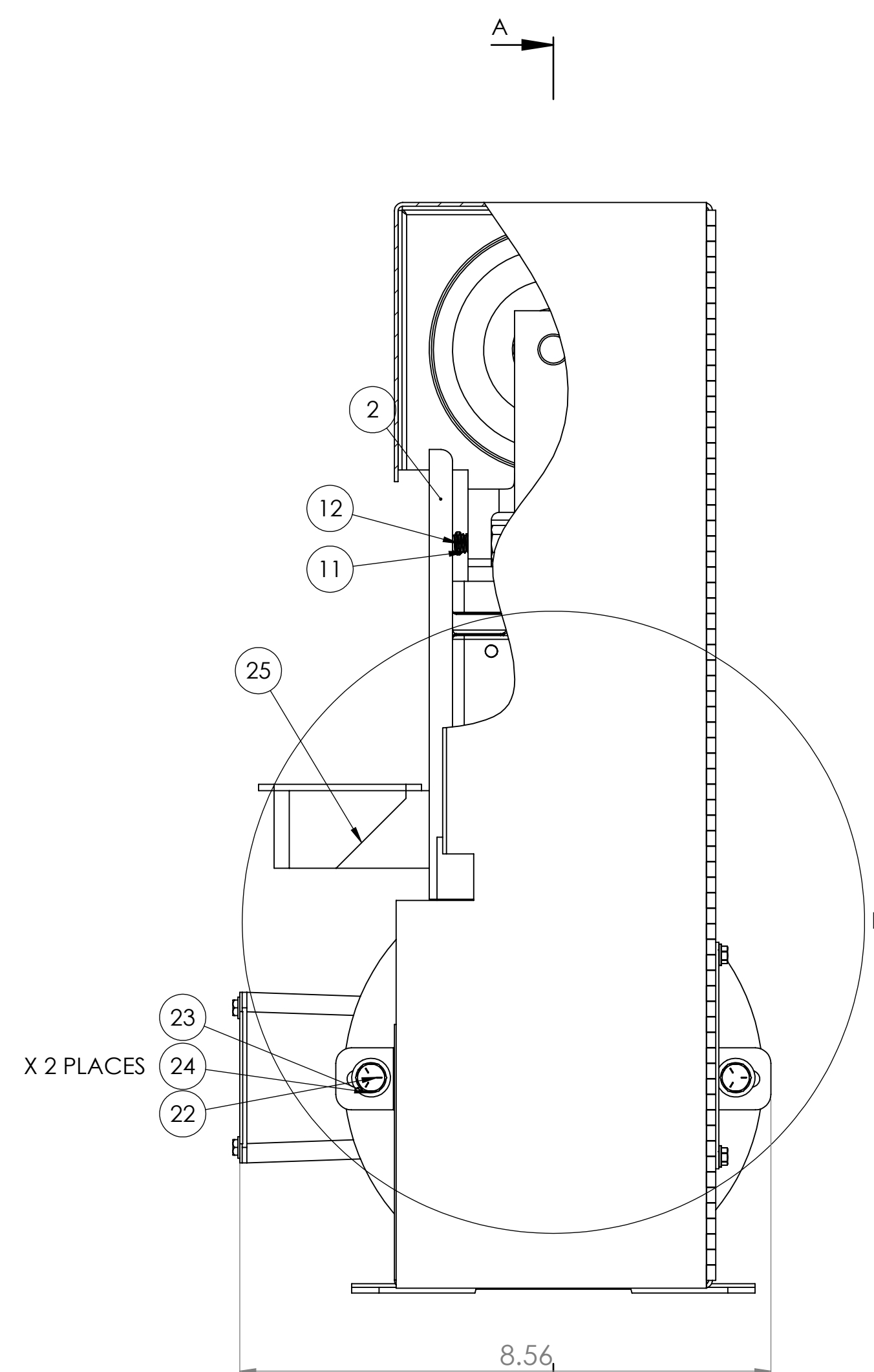

RIGHT SIDE VIEW

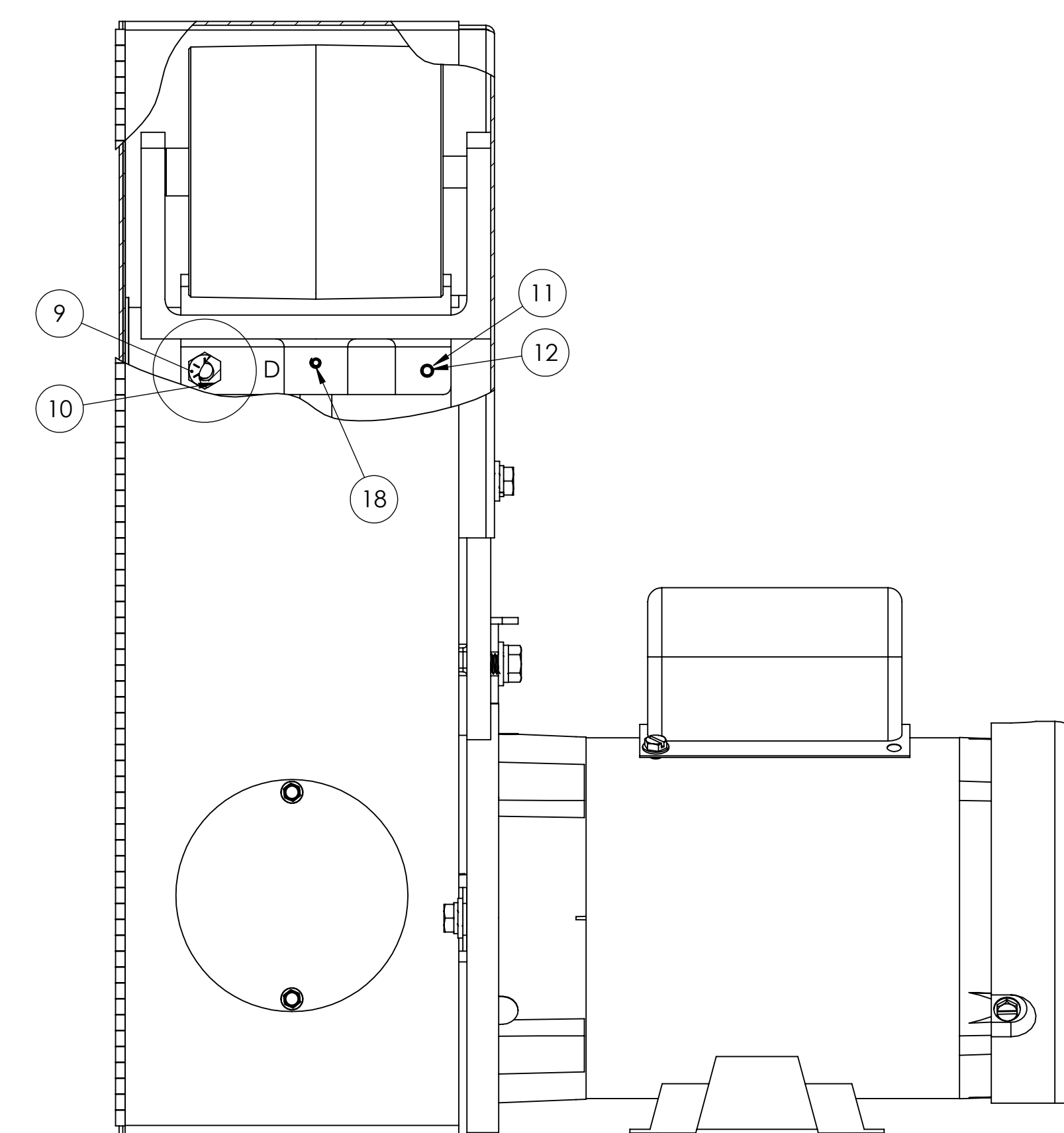

BACK VIEW

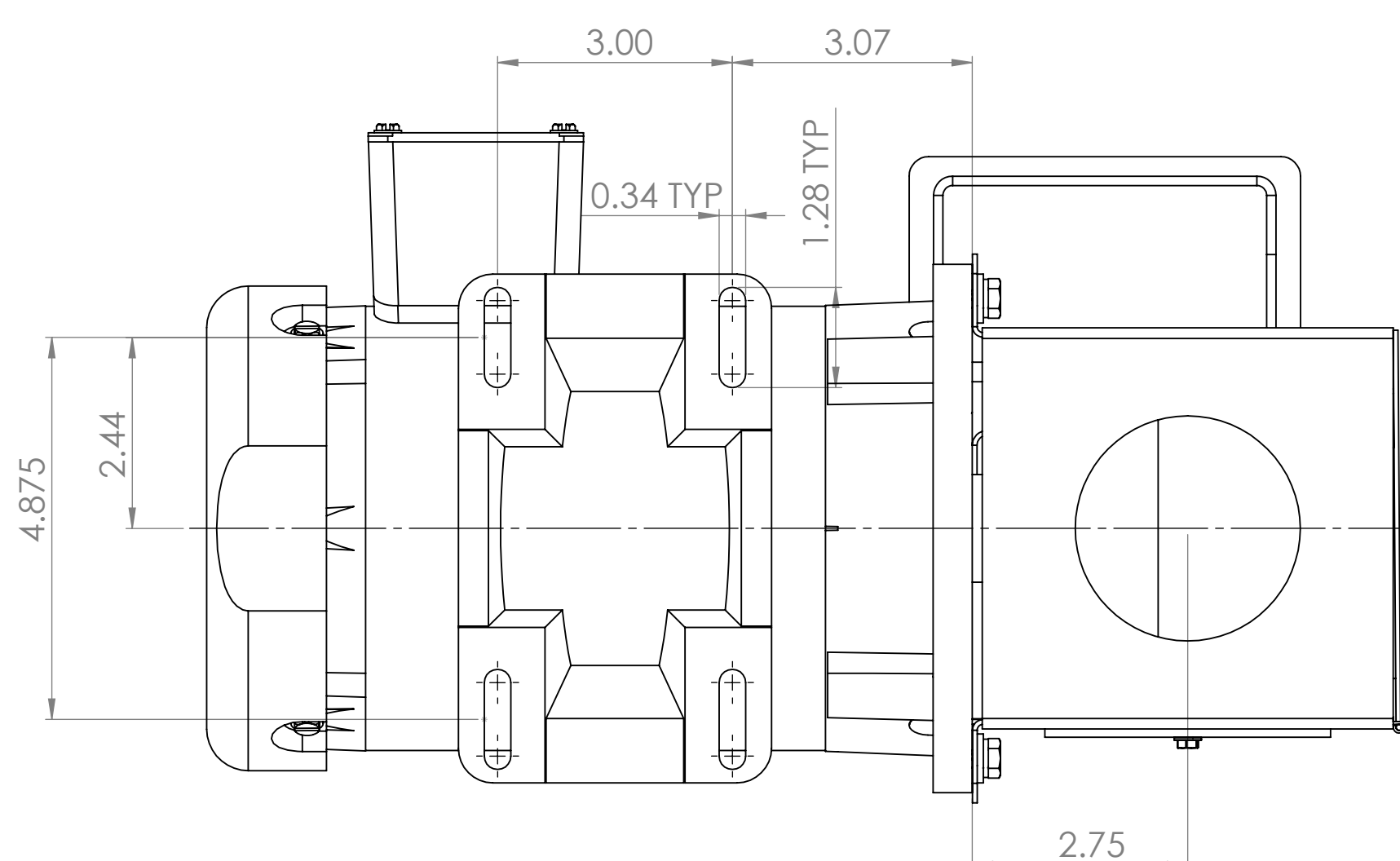

BOTTOM VIEW

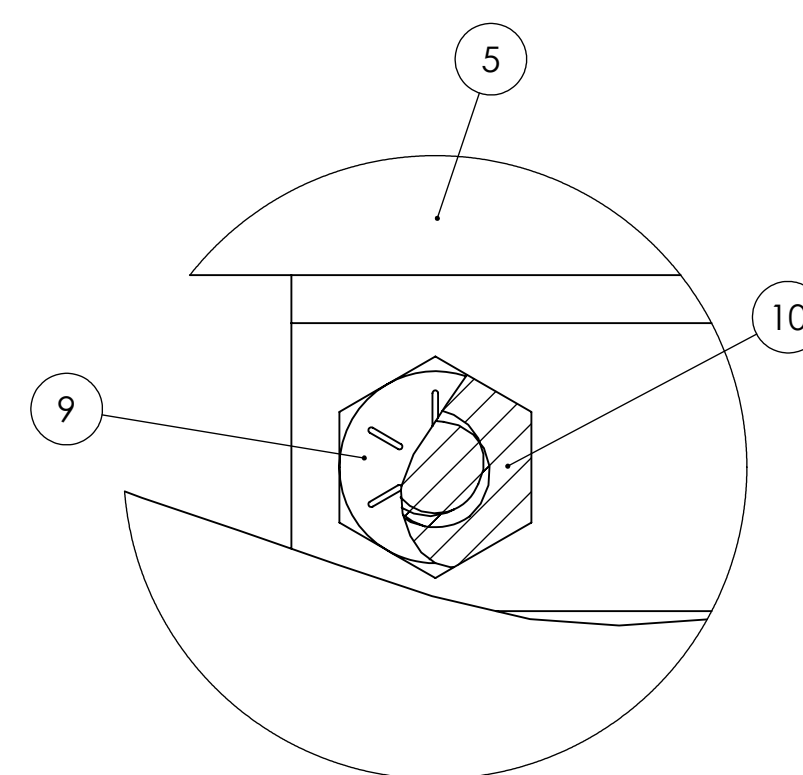

DETAIL D
SCALE 2:1
TRACKING NUT
AND BOLT

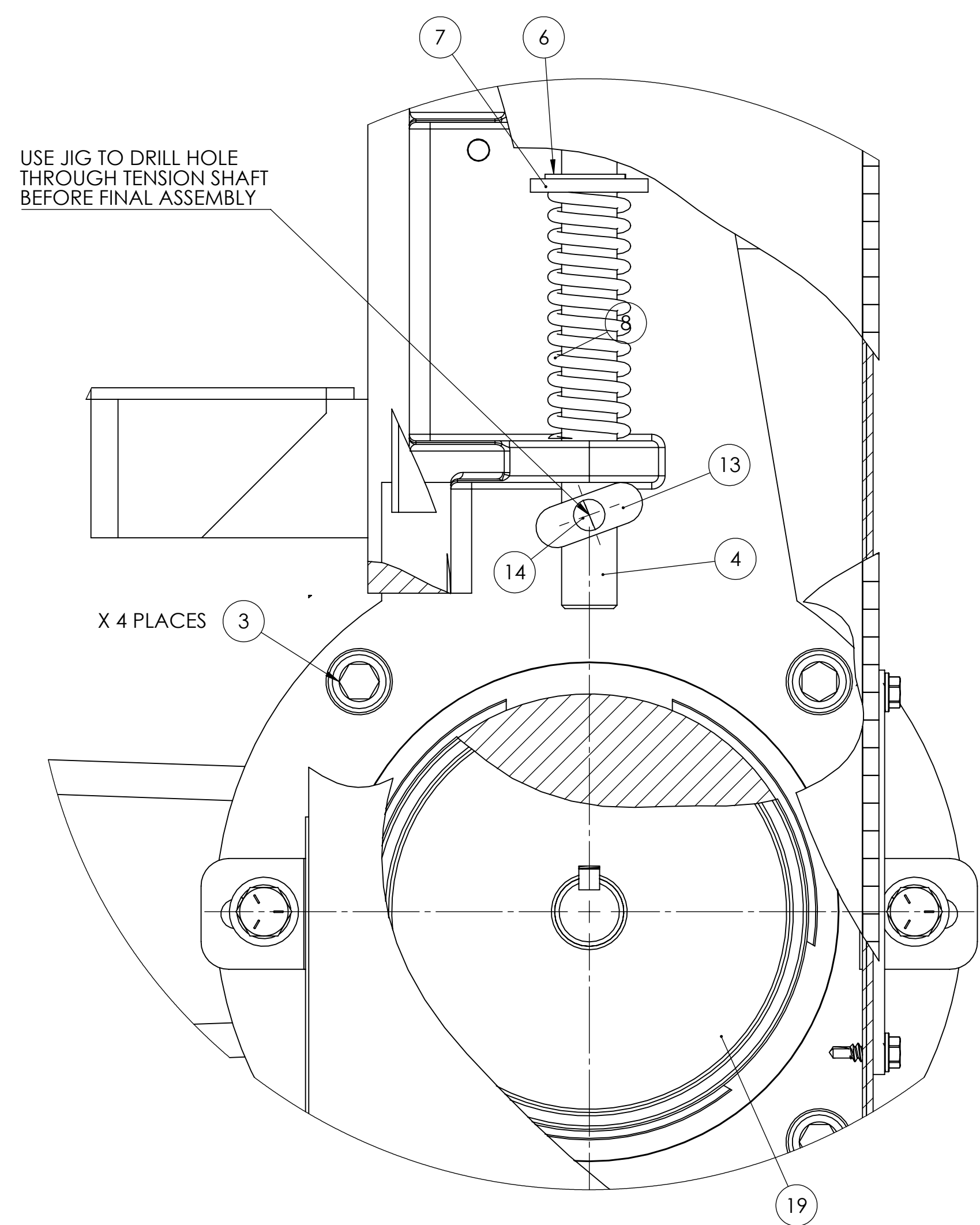

DETAIL B
DETAIL OF MAIN ARM,
TENSION SHAFT,
SPRING, AND CAM

ITEM NO.	PART NUMBER	DESCRIPTION	QTY.
1	486-022	1/2HP MOTOR FOR 2FSM, S4S AND S612V VAC MOTOR	1
2	291-002	CAST IRON FRAME WITH PLATEN FOR S4, S4S, DS10-4	1
3	SHCA037012	3/8-16 X 3/4 SHCS	4
4		YOKE SHAFT FOR S4 SANDER	1
5	960-002YA	YOKE AND TENSION SHAFT ASSEMBLY	1
6	EERR0.5	EERR1/2 1/2" E RETAINING RING	2
7	UFWZ050	1/2 USS F/W Z	1
8	697-010	SPRING, TENSION FOR S4 SANDERS	1
9	HHC5031020	TRACKING SCREW	1
10	FHN5031	5/16-18 FHN GR5 ZINC	1
11	697-011	TRACKING SPRING FOR S4	1
12	CRM2010024	10-24 X 1-1/2 COMBO ROUND M/S Z	1
13	129-008	CAM FOR S4 TENSION SHAFT	1
14	RUDZ007008	#7 X 1/2 RD U-DRIVE SCREW Z	1
15	701-008	SPINDLE, IDLER FOR S4, S460 SANDERS	1
16	560-006	IDLER PULLEY S4 W BEARINGS FOR S4S AND S460	1
17	123-003	COLLAR FOR S4	1
18	SSKA010004	10-24 X 1/4 SOC SET KNURL PT	2
19	560-005	PULLEY, DRIVE (ALUMINUM) FOR S4, S4S, S460D	1
20	SSKA025006	1/4-20 X 3/8 SOC SET KNURL PT.	1
21	342-022	GUARD, OSHA FOR S4S, DS10-4S SANDER	1
22	HHC5025008	1/4-20 X 1/2 HHCS GR5 Z	4
23	UFWZ025	1/4 USS F/W Z	4
24	SLWZ025	1/4 SPLIT L/W Z	4
25	829-004	WORK TABLE FOR 2', 4', DS10-4 SANDERS	1
26	HHC5031012	5/16-18 X 3/4 HHCS GR5 Z	1
27	UFWZ031	5/16 USS F/W Z	1
28	SLWZ031	5/16 SPLIT L/W Z	1

PROPRIETARY/CONFIDENTIAL
THE INFORMATION CONTAINED IN THIS DRAWING IS THE SOLE PROPERTY OF KALAMAZOO. IT IS TO BE USED FOR THE MANUFACTURE OF THE PARTS AND ASSEMBLIES IDENTIFIED HEREIN. ANY REPRODUCTION IN PART OR AS A WHOLE WITHOUT THE WRITTEN PERMISSION OF KALAMAZOO COMPANY IS PROHIBITED.

UNLESS OTHERWISE SPECIFIED:	NAME	DATE
DIMENSIONS ARE IN INCHES	DRAWN BY	
TOLERANCES:	CHECKED	
FRACTIONS: 1/16	ENG APPR	
ANGULAR: 30 MIN	MFG APPR	
DECIMALS: 0.0005		
THREE PLACE DECIMAL		
INTERFERENCE GEOMETRIC TOLERANCES PER		
ASME Y14.5		

APPLICATOR: _____ USED ON: _____ FINISH: _____
DO NOT SCALE DRAWING

KALAMAZOO
TITLE: **S4S BELT SANDER ASSEMBLY**
DWG. NO.: **E**
SCALE: 1:1 WEIGHT: _____ SHEET 1 OF 1

ITEM NO.	PART NUMBER	DESCRIPTION	QTY.
1	124-001	CABINET, VACUUM FOR DCV-4	1
2	833-001	TOP, CABINET FOR DCV-4 VACUUM (S4S SANDER MOUNT)	1
3	HWTZ008008	#8 X 1/2 HWH TEKS Z	6
4	SLWZ010	#10 SPLIT L/W Z	6
5	MSWZ010	#10 M.S. F/W Z	6

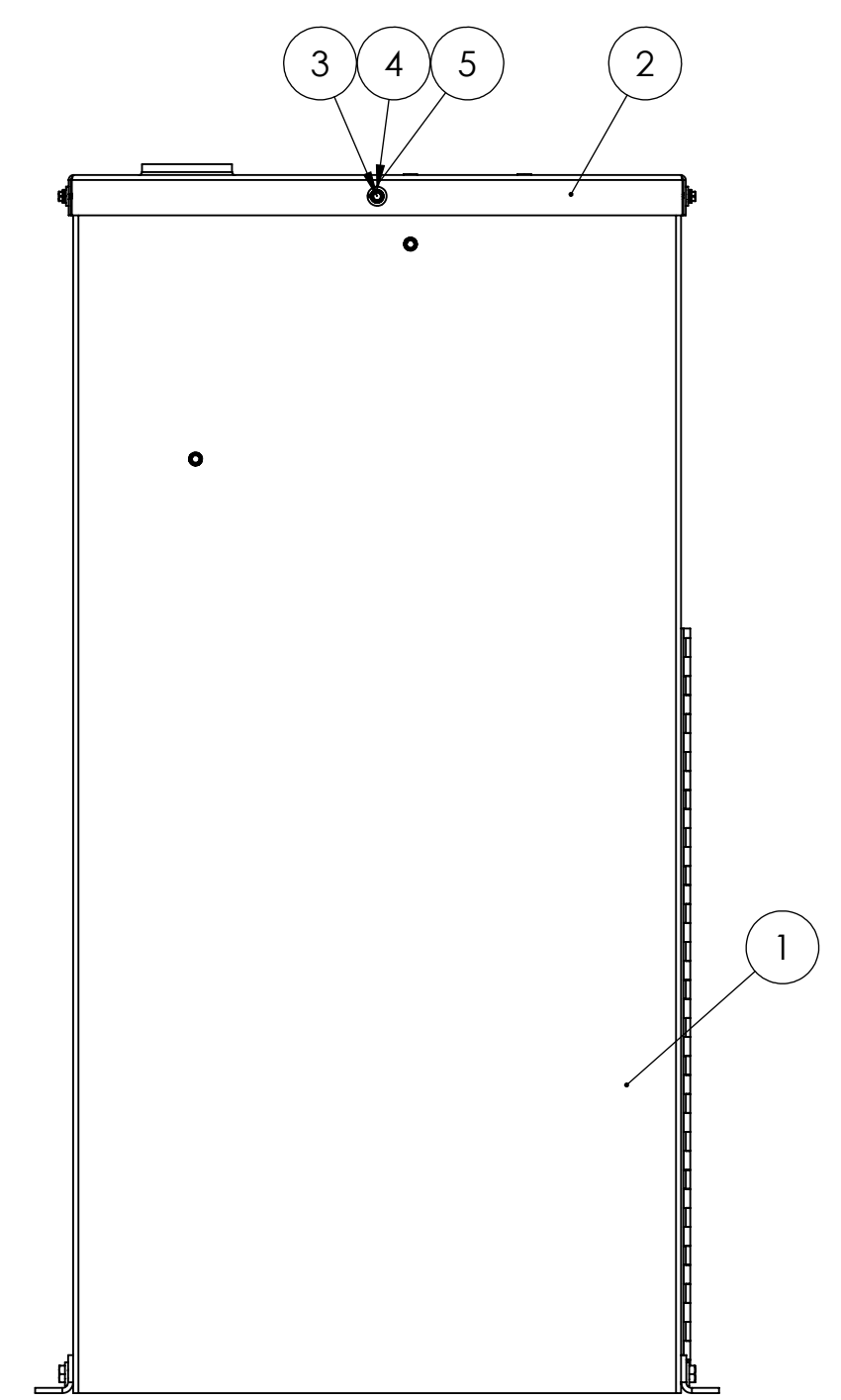
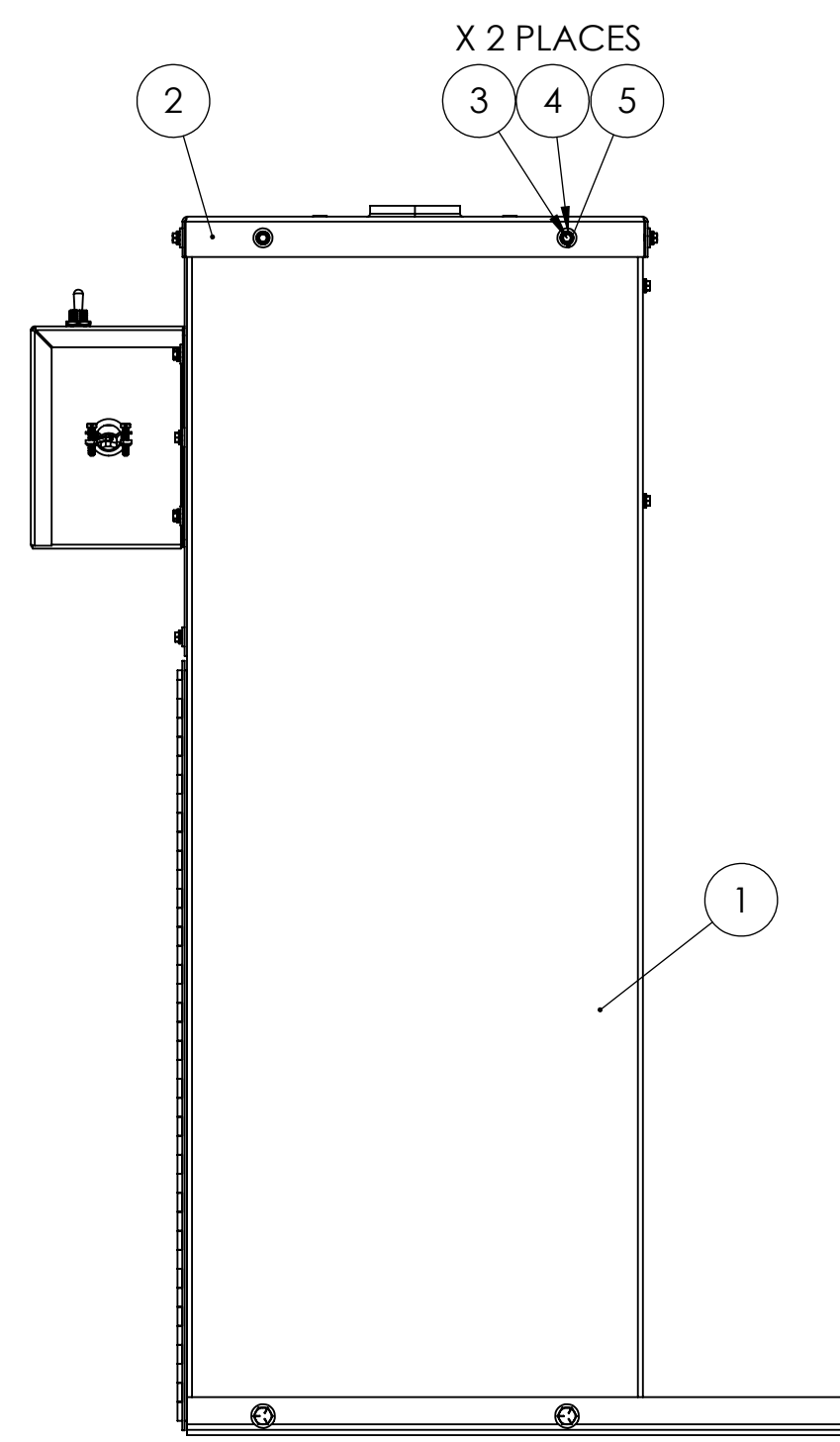
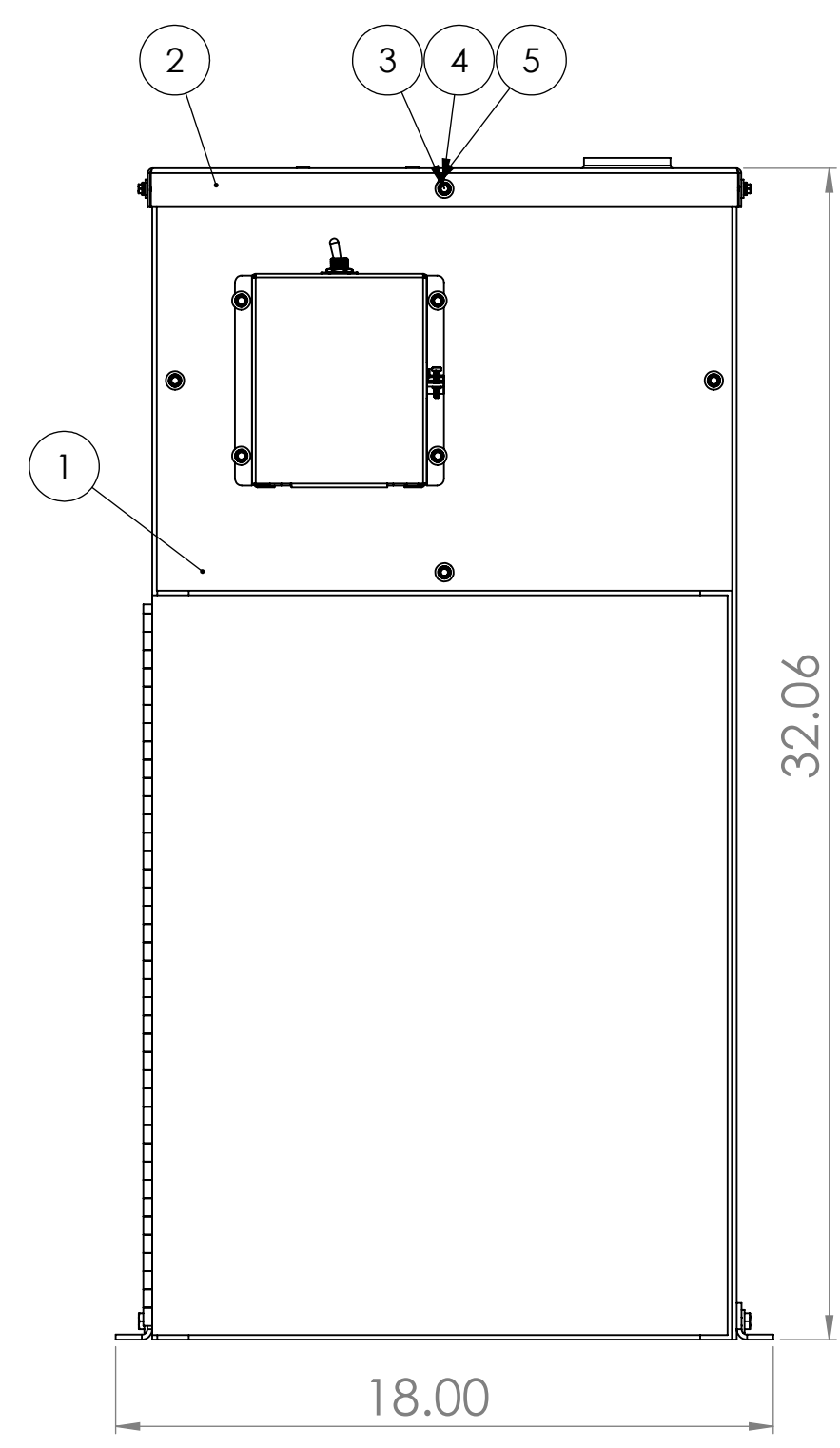
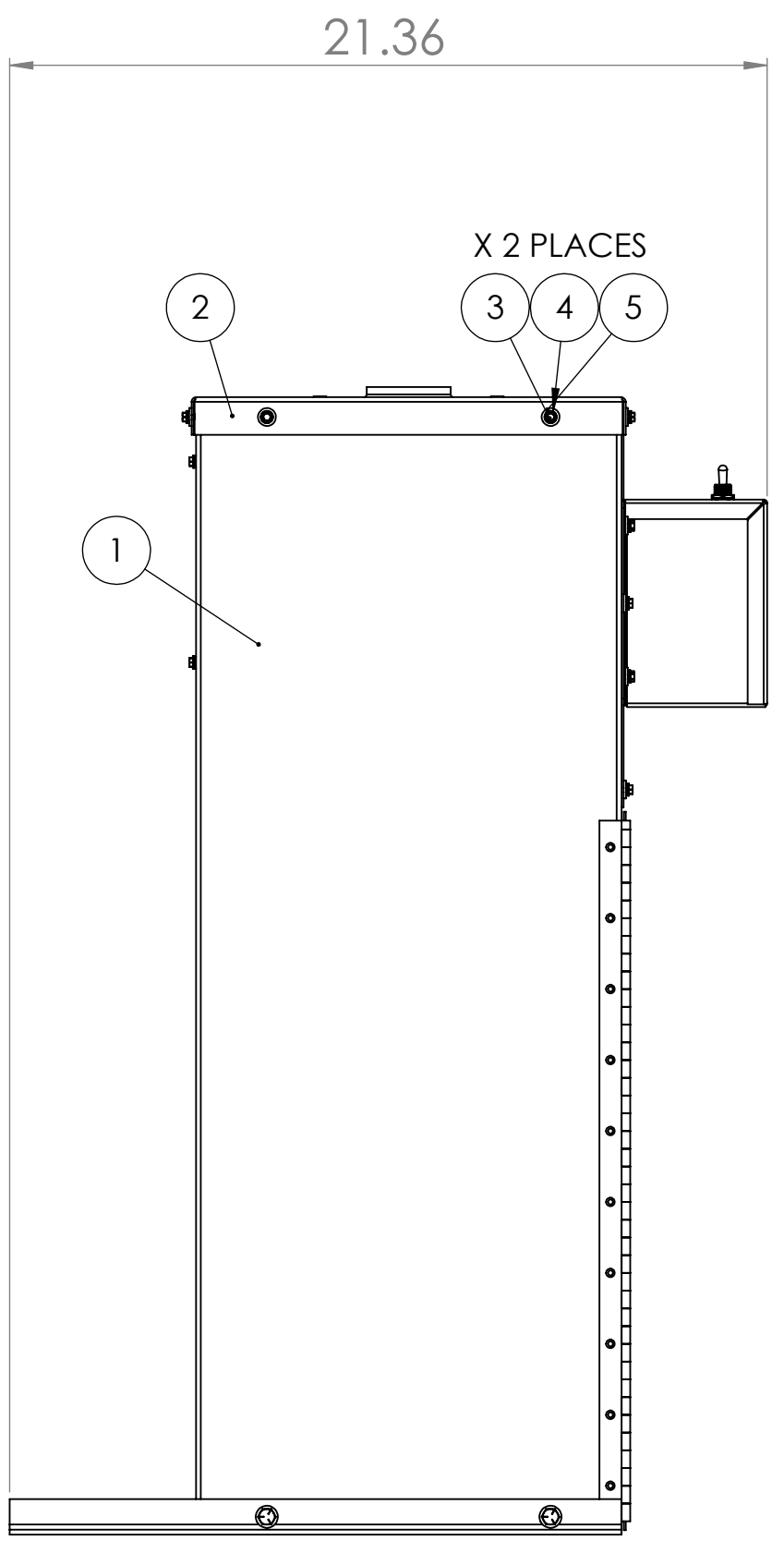
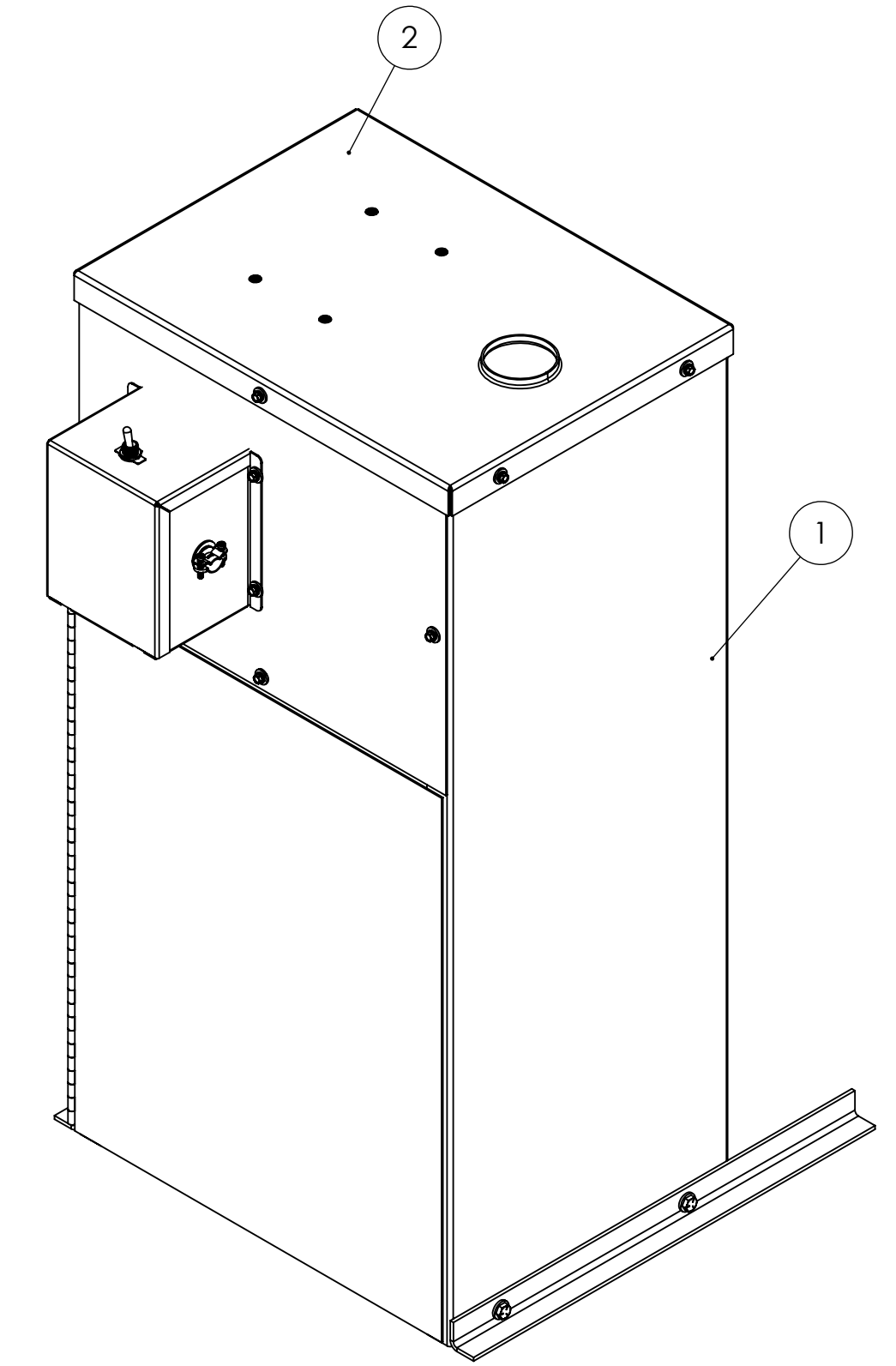
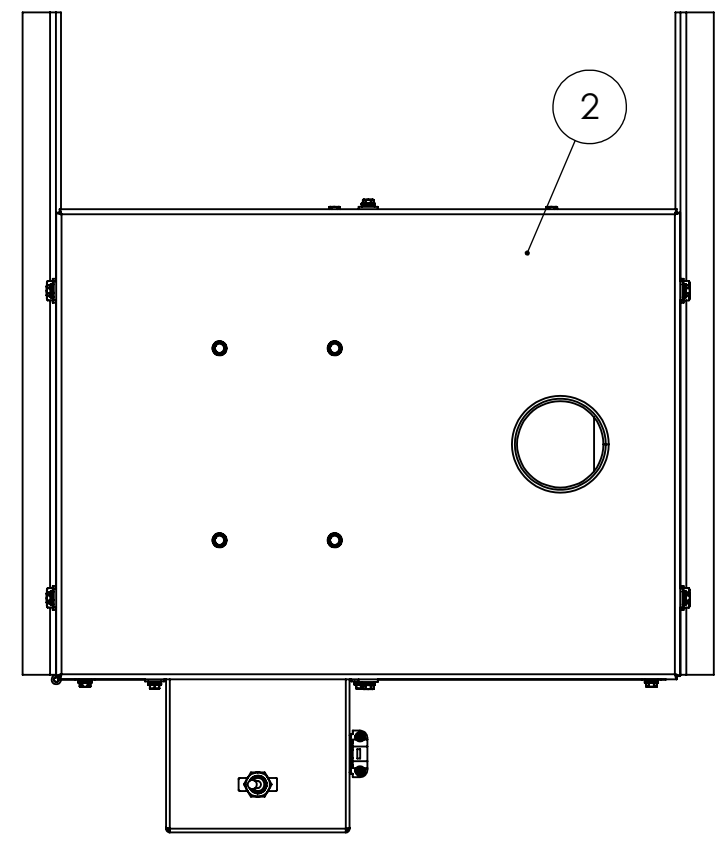

PLEASE CONSULT DRAWING 124-001 FOR CABINET DETAILS

PROPRIETARY AND CONFIDENTIAL
 THE INFORMATION CONTAINED IN THIS DRAWING IS THE SOLE PROPERTY OF KALAMAZOO INDUSTRIES, INC. ANY REPRODUCTION IN PART OR AS A WHOLE WITHOUT THE WRITTEN PERMISSION OF KALAMAZOO INDUSTRIES, INC. IS PROHIBITED.

UNLESS OTHERWISE SPECIFIED:		NAME	DATE
DIMENSIONS ARE IN INCHES			
FRACTIONAL: ±	DRAWN		
ANGULAR: MATCH ± BEND ±	CHECKED		
TWO PLACE DECIMAL: ±	ENG APPR.		
THREE PLACE DECIMAL: ±	MFG APPR.		
INTERPRET GEOMETRIC TOLERANCING PER: MATERIAL	Q.A.		
FINISH	COMMENTS:		
APPLICATION	DO NOT SCALE DRAWING		



TITLE: DCV-4 DUST COLLECTOR FOR S4SV APPLICATION

SIZE DWG. NO. REV
D DCV-4(S4SV)
 SCALE: 1:5 WEIGHT: SHEET 1 OF 1