

KI **KALAMAZOO** INDUSTRIES, INC. KALAMAZOO, MI

PH: (269) 382-2050

www.kalamazooind.com



S4S AND S4 BELT SANDER MANUAL



MADE IN USA

KI **KALAMAZOO** INDUSTRIES, INC. KALAMAZOO, MI

PH: (269) 382-2050

www.kalamazooind.com

INSPECTION

If these goods are damaged in transit, the **DELIVERING TRANSPORTATION COMPANY** is required by law to make notation of damages on the freight bill. If in your opinion, there may be concealed damage, they are required to make an inspection after goods are unpacked. Transportation rates are made in proportion to damage. Therefore, the carrier and **NOT** the shipper should be charged with any loss or damage. Any claim should be filled with the delivering **TRANSPORTATION COMPANY. PLEASE DO NOT RETURN GOODS TO US WITHOUT OUR RGA NUMBER AND SHIPPING INSTRUCTIONS.**

NOTE: SEE NEXT PAGE FOR RETURN POLICY AND WARRANTY.

READ OPERATING INSTRUCTIONS AND PRECAUTIONS BEFORE USING EQUIPMENT OPERATING INSTRUCTIONS

1. Disconnect power before making any adjustments.
2. Abrasive belt rotation is counter-clockwise. If the abrasive belt is lap spliced be sure of correct rotation. Butt spliced belts are bi-directional
3. Belt tension is pre-set with internal spring. No belt tension adjustment is needed.
4. **Belt changing: Disconnect power, squeeze belt manually, align flip cam to hold tension spring closed (A), remove belt and install new belt, move flip cam back to position (B) to tension.**
5. **Belt tracking: Tracking screw twits yoke to center belt. With power OFF spin belt manually to verify belt tracking, adjust tracking screw to center belt, tighten jam nut to lock tracking screw. Jog belt with power ON to check belt centering or "tracking".**
6. Always keep the work table within 1/8" of sanding belt. This will avoid pinching material between sanding belt and platen.
7. Examine the abrasive belt carefully before use. Never use an abrasive belt with a nicked or cut edge, crease or handling damage.
8. If you are using a dust collector, bags should be emptied frequently during use to maintain efficiency and prevent buildup of combustible materials.

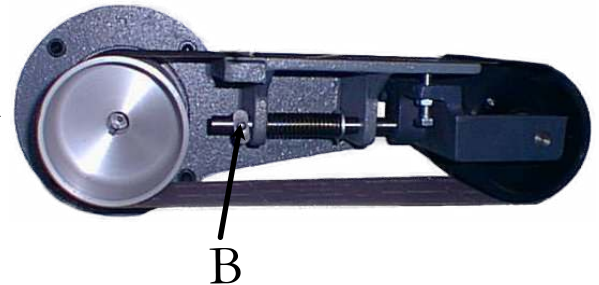
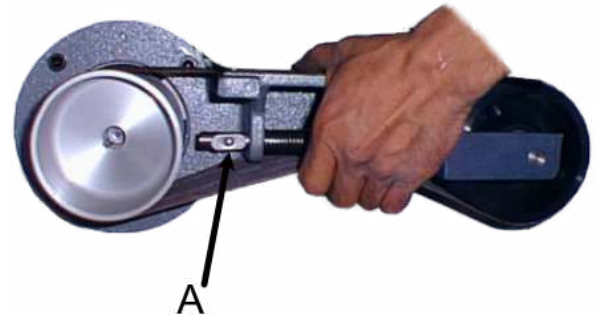

KI **KALAMAZOO**
INDUSTRIES, INC.
KALAMAZOO, MI



PH: (269) 382-2050

www.kalamazooind.com

WARRANTY

All products are guaranteed for a period of one year from receipt of order to the original purchaser, against defects in material workmanship under normal use. Electric motors are warranted by the motor manufacturer for a period of one year and will be repaired by the nearest motor repair station. If non-repairable, they will be replaced by Kalamazoo Industries. Please call for instructions (269) 382-2050.

RETURN POLICY

Authorization must be obtained before returning merchandise. Please call our customer service department for a return authorization number (269) 382-2050. Please include with your return a copy of your invoice of packing slip. All material must be new and unused in the original packaging. Material must be sent back prepaid (unless otherwise indicated) by Kalamazoo Industries. Credit upon inspection at Kalamazoo Industries. All returns will be subject to a 10% restock charge. Used merchandise is non-returnable. No returns will be accepted after one year of invoice date.

BELT SANDER SAFETY

- READ THE OPERATING INSTRUCTIONS BEFORE RUNNING MACHINE.
- ALWAYS WEAR SAFETY GLASSES OR A FULL FACE SHIELD FOR PROTECTION.
- KEEP HANDS CLEAR OF THE SANDING AREA.
- NEAR WEAR GLOVES OR LOOSE FITTING CLOTHES WHEN OPERATING THIS MACHINE.
- ALWAYS KEEP HAIR TIED BACK OR COVERED.
- LET MACHINE ROTATION COME TO A FULL STOP BEFORE CHANGING BELT.
- KEEP SAFETY GUARDS IN PLACE. DO NOT ALTER GUARD OR MACHINE IN ANYWAY. ANY ALTERATIONS TO GUARDS OR MACHINE COULD CAUSE SERIOUS INJURY.
- ALL BELT SANDERS SHOULD BE OPERATED IN A WELL-VENTILATED AREA. THE DUST CREATED WHEN SOME MATERIALS ARE SANDED CAN BE HARMFUL. DUST MASKS ARE RECOMMEND AS A PRACTICAL MEAN OF MINIMIZING DUST INHALATION. FUMES FROM OTHER OTHER SOURCES CAN ALSO CAUSES FIRES WHEN INTACT WITH SANDING SPARK.
- SPARKS CREATED BY SANDING SHOULD BE DIRECTED DOWNWARD AND AWAY FROM THE FACE AND BODY. DON NOT GRIND NEAR FLAMMABLE MATERIAL.
- ELECTRIC SANDING MACHINES ARE NOT INTENDED FOR USE IN OR NEAR WATER. THIS INCLUDES AN OPERATOR STANDING ON A WET FLOOR OR WORKING AROUND CONTAINERS OF WATER OR OTHER CONDUCTIVE LIQUIDS.

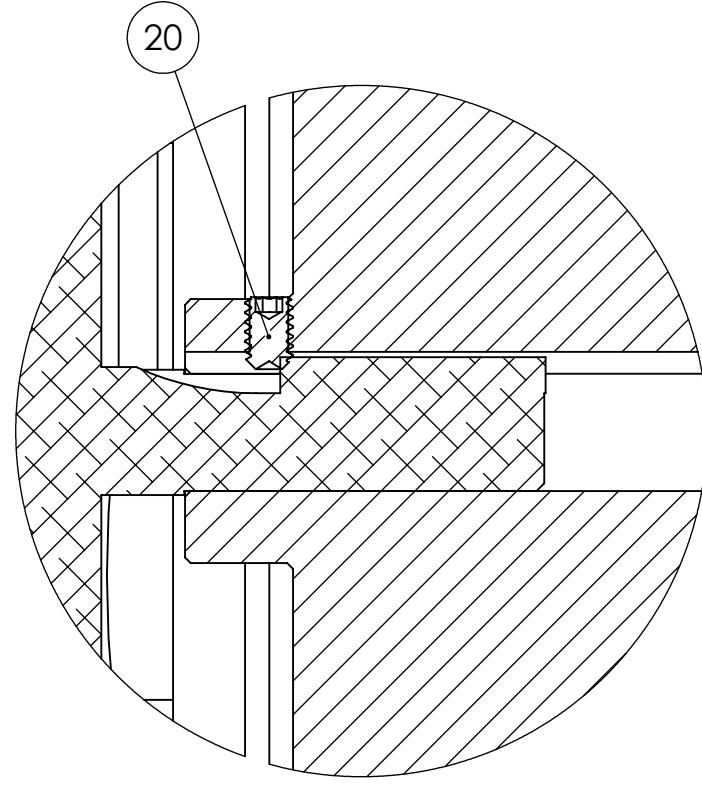
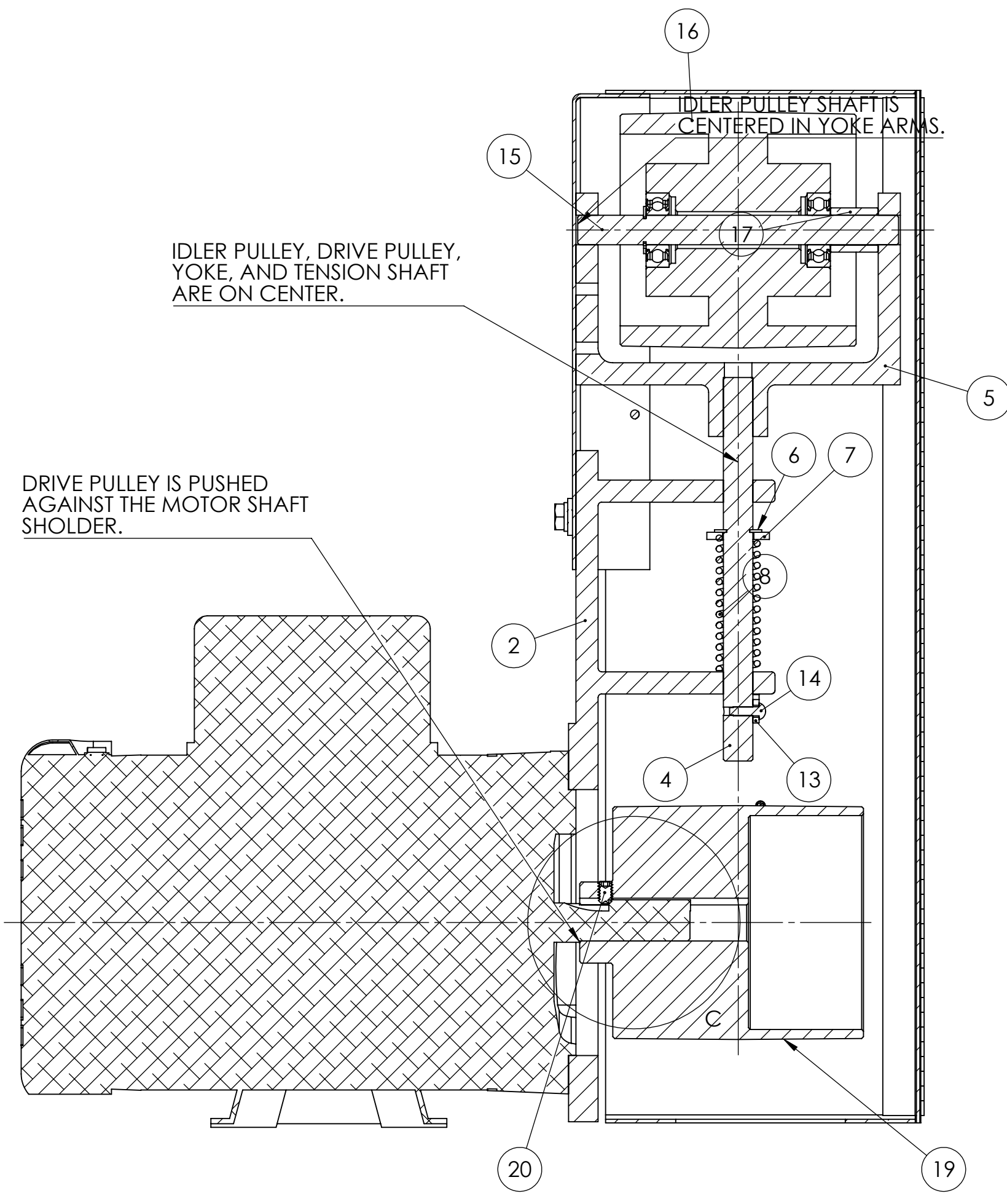

DETAIL C
DETAIL OF DRIVE PULLEY SET-SCREW

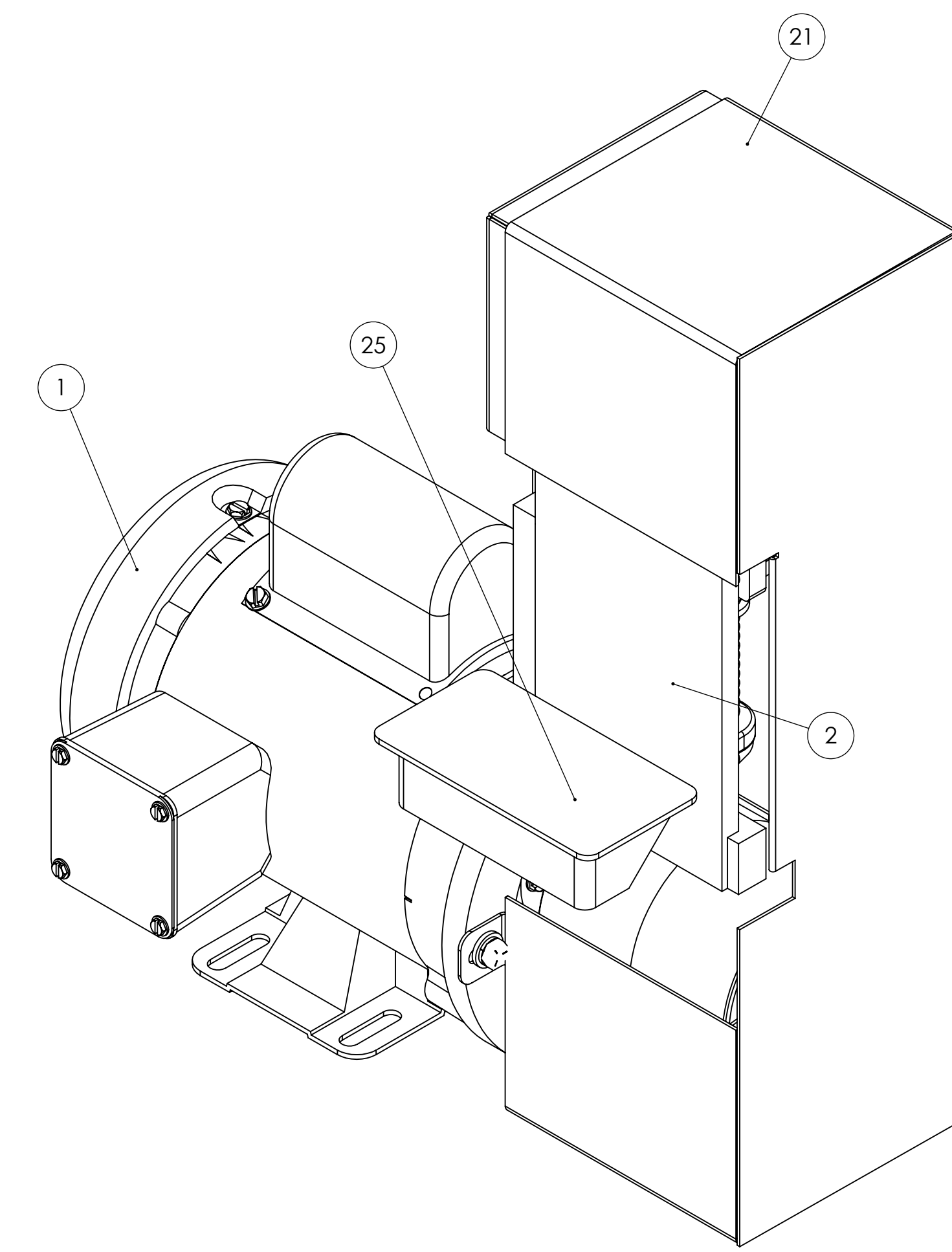

ITEM NO.	PART NUMBER	DESCRIPTION	QTY.
1	486-022	1/2HP MOTOR FOR 2FSM, S4S AND S612V VAC MOTOR	1
2	291-002	CAST IRON FRAME WITH PLATEN FOR S4, S4S, DS10-4	1
3	SHCA037012	3/8-16 X 3/4 SHCS	4
4		YOKE SHAFT FOR S4 SANDER	1
5	960-002YA	YOKE AND TENSION SHAFT ASSEMBLY	1
6	EERR0.5	EERR1/2 1/2" E RETAINING RING	2
7	UFWZ050	1/2 USS F/W Z	1
8	697-010	SPRING, TENSION FOR S4 SANDERS	1
9	HHC5031020	TRACKING SCREW	1
10	FHN5031	5/16-18 FHN GR5 ZINC	1
11	697-011	TRACKING SPRING FOR S4	1
12	CRMZ010024	10-24 X 1-1/2 COMBO ROUND M/S Z	1
13	129-008	CAM FOR S4 TENSION SHAFT	1
14	RUDZ007008	#7 X 1/2 RD U-DRIVE SCREW Z	1
15	701-008	SPINDLE, IDLER FOR S4, S460 SANDERS	1
16	560-006	IDLER PULLEY S4 W BEARINGS FOR S4S AND S460	1
17	123-003	COLLAR FOR S4	1
18	SSKA010004	10-24 X 1/4 SOC SET KNURL PT	2
19	560-005	PULLEY, DRIVE (ALUMINUM) FOR S4, S4S, S460D	1
20	SSKA025006	1/4-20 X 3/8 SOC SET KNURL PT.	1
21	342-022	GUARD, OSHA FOR S4S, DS10-4S SANDER	1
22	HHC5025008	1/4-20 X 1/2 HHCS GR5 Z	4
23	UFWZ025	1/4 USS F/W Z	4
24	SLWZ025	1/4 SPLIT L/W Z	4
25	829-004	WORK TABLE FOR 2', 4', DS10-4 SANDERS	1
26	HHC5031012	5/16-18 X 3/4 HHCS GR5 Z	1
27	UFWZ031	5/16 USS F/W Z	1
28	SLWZ031	5/16 SPLIT L/W Z	1

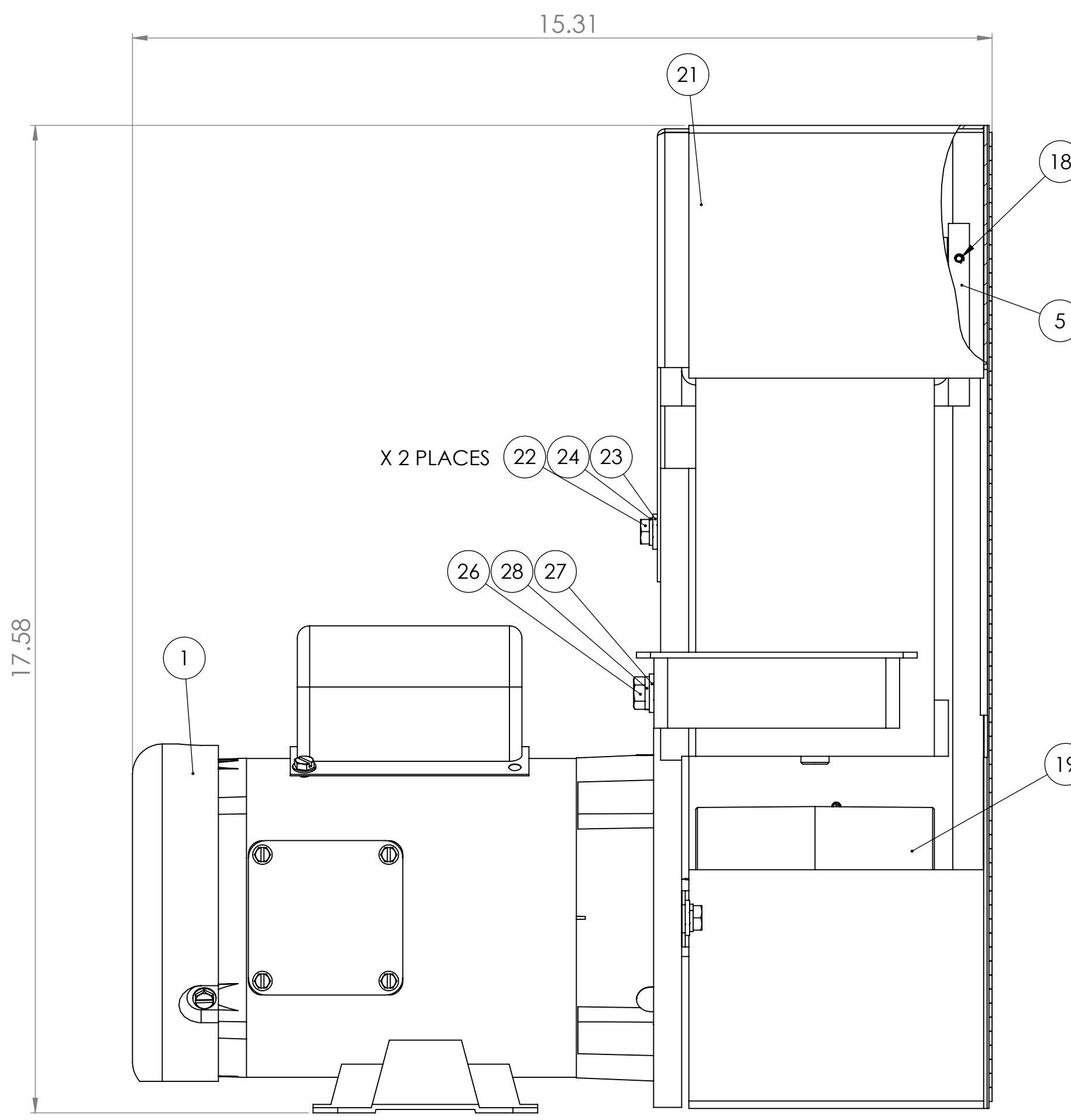

FRONT VIEW

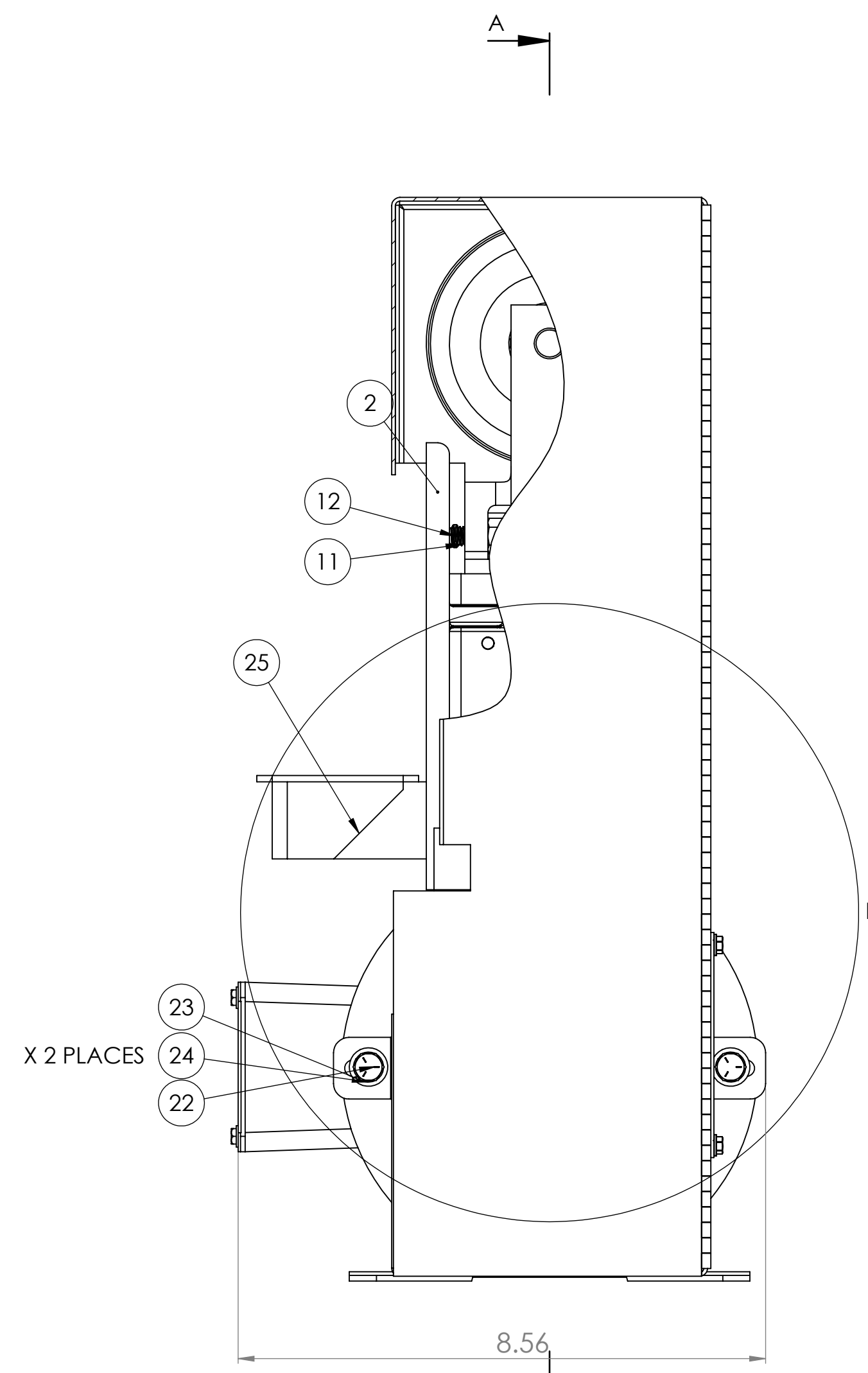

RIGHT SIDE VIEW

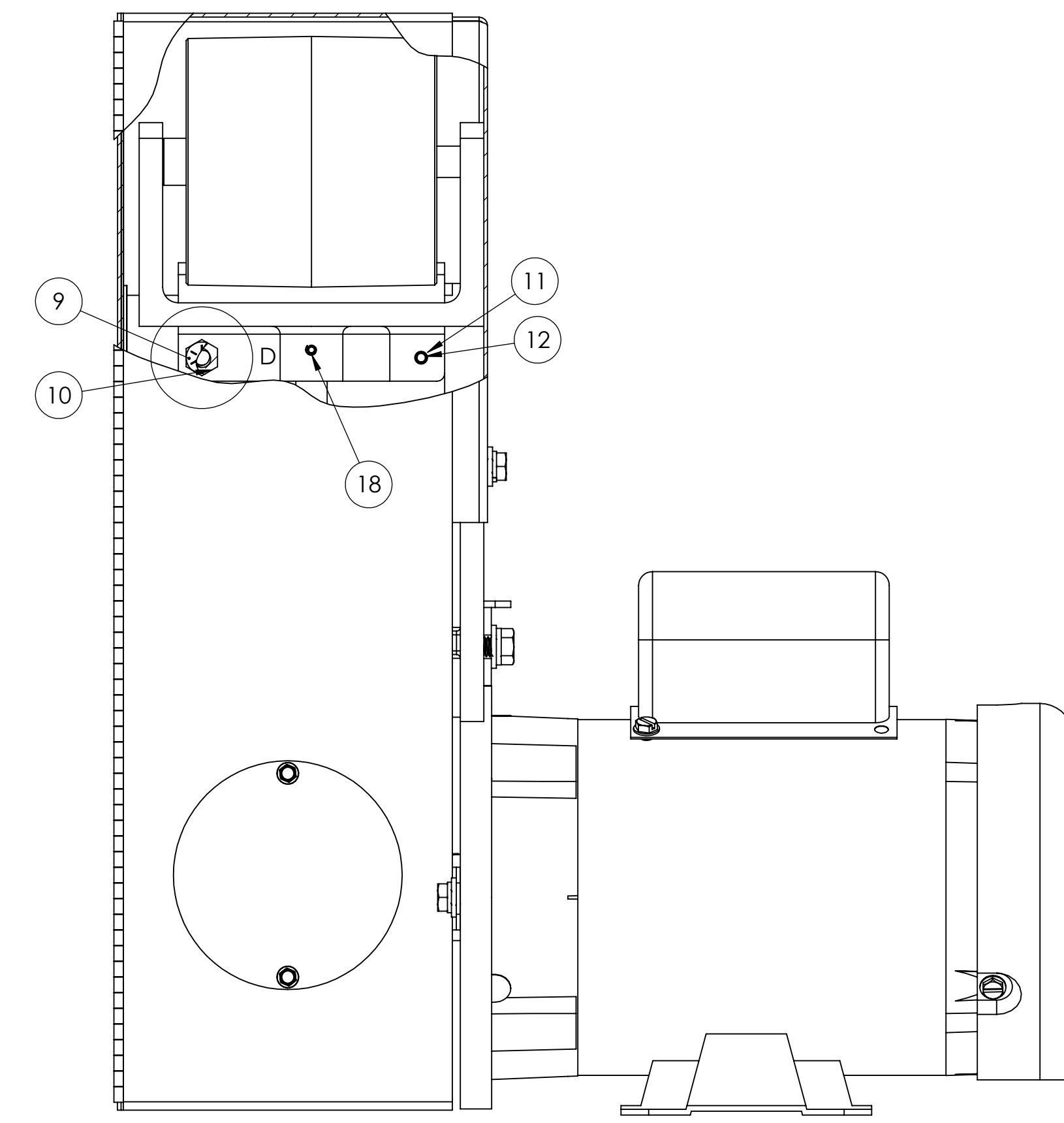

BACK VIEW

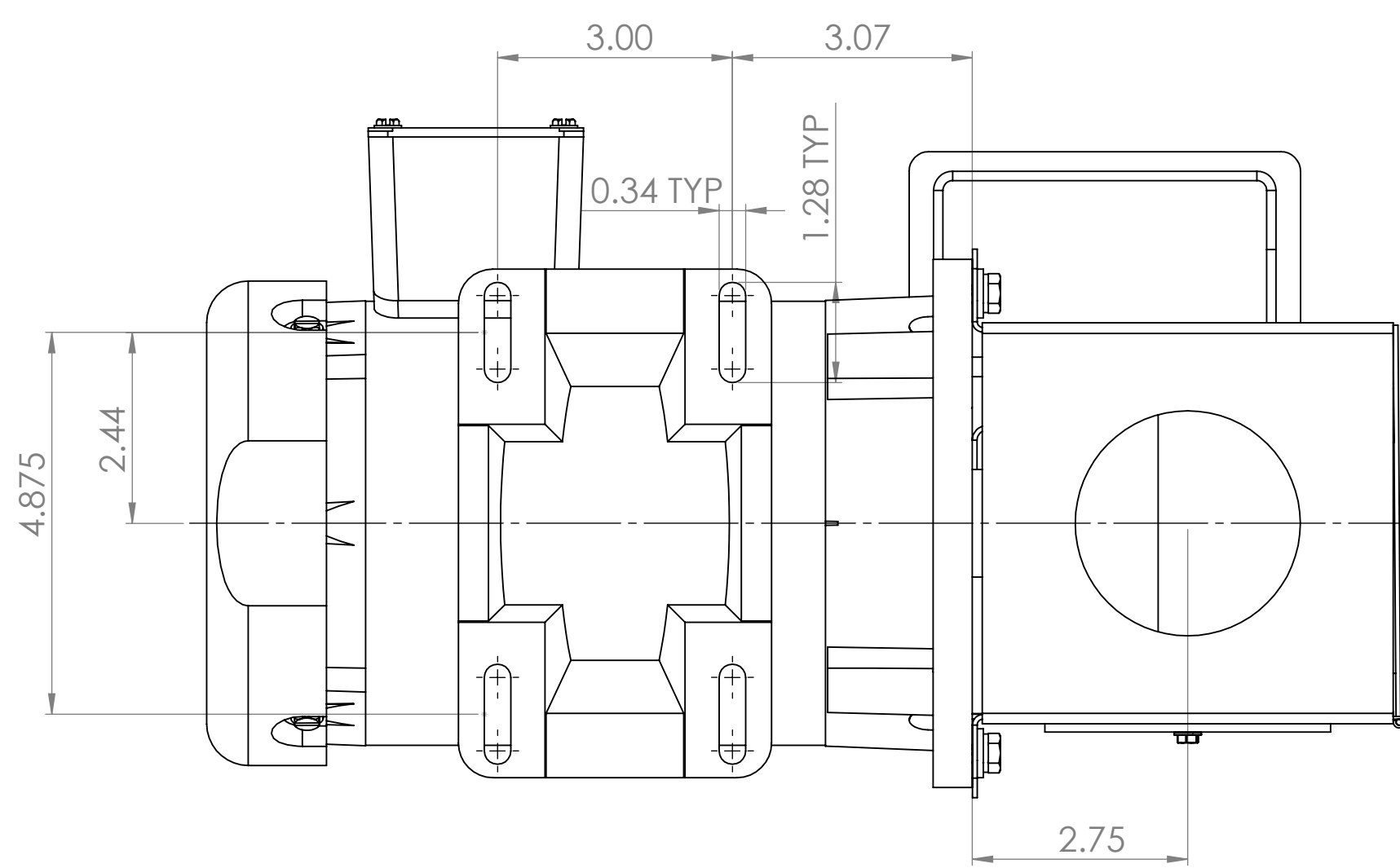

BOTTOM VIEW

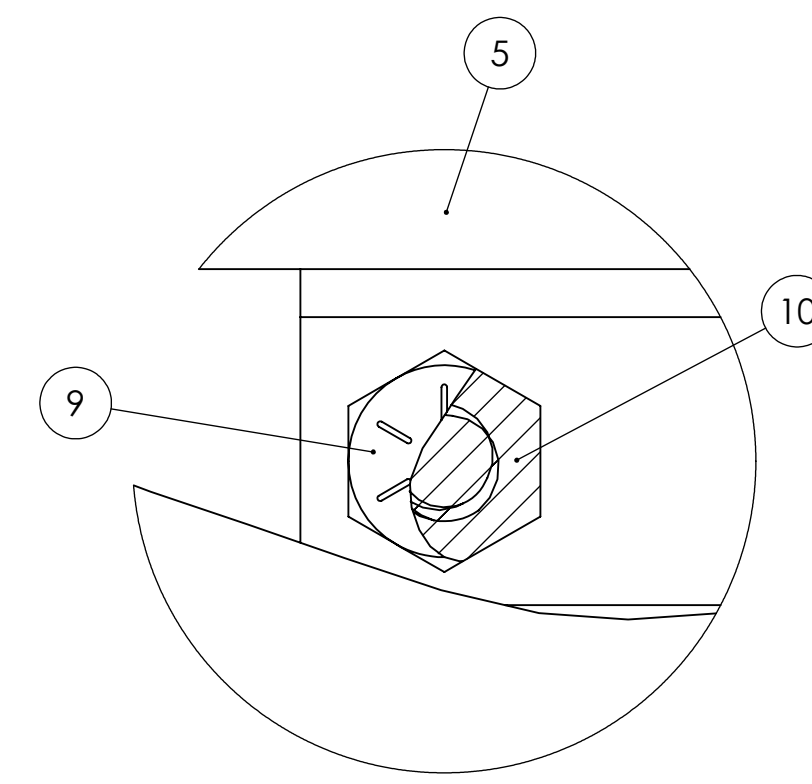

DETAIL D
SCALE 2:1
TRACKING NUT AND BOLT

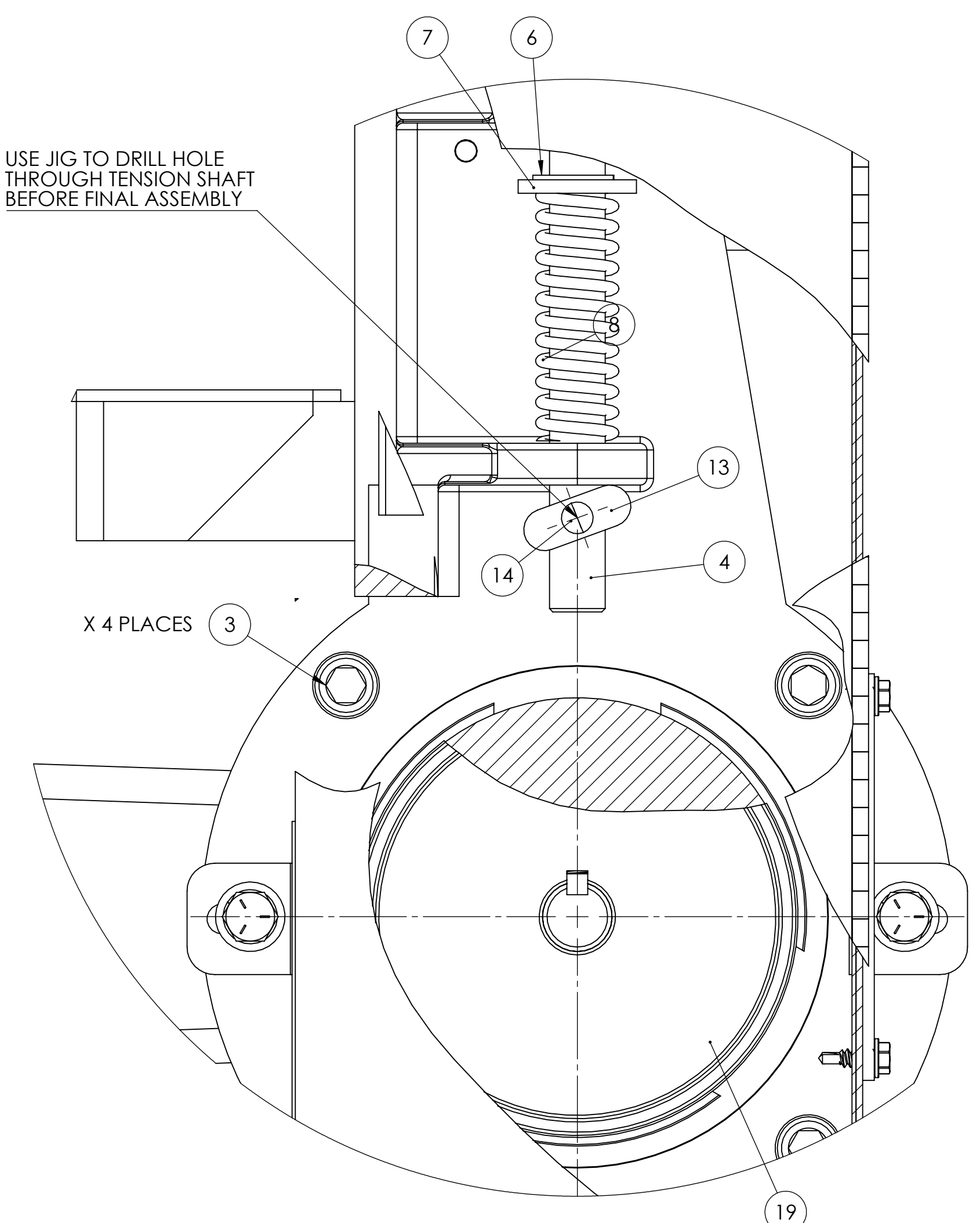

DETAIL B
DETAIL OF MAIN ARM, TENSION SHAFT, SPRING, AND CAM

PROPRIETARY AND CONFIDENTIAL. THE INFORMATION CONTAINED IN THIS DRAWING IS THE SOLE PROPERTY OF KALAMAZOO. IT IS TO BE USED FOR THE MANUFACTURE OF THE PARTS IDENTIFIED HEREIN. REPRODUCTION IN PART OR AS A WHOLE WITHOUT THE WRITTEN PERMISSION OF KALAMAZOO IS PROHIBITED.

UNLESS OTHERWISE SPECIFIED:	NAME	DATE
DIMENSIONS ARE IN INCHES	DRAWN BY	
TOLERANCES:	CHECKED	
FRACTIONS: 1/16	ENG APPR	
ANGULAR: 30/45/60/90/120/135/150/180	WFO APPR	
PROFILES: DECIMAL 2		
THREE PLACE DECIMAL 2		
INTERFERENCE GEOMETRIC TOLERANCES: FIT		
MATERIAL:	COMMENTS:	
NEATNESS	USED ON	FINISH
APPLICATION	DO NOT SCALE DRAWING	

KALAMAZOO
TITLE: S4S BELT SANDER ASSEMBLY
DWG. NO.: S4S BELT SANDER ASSEMBLY
SCALE: 1:1 WEIGHT: SHEET 1 OF 1

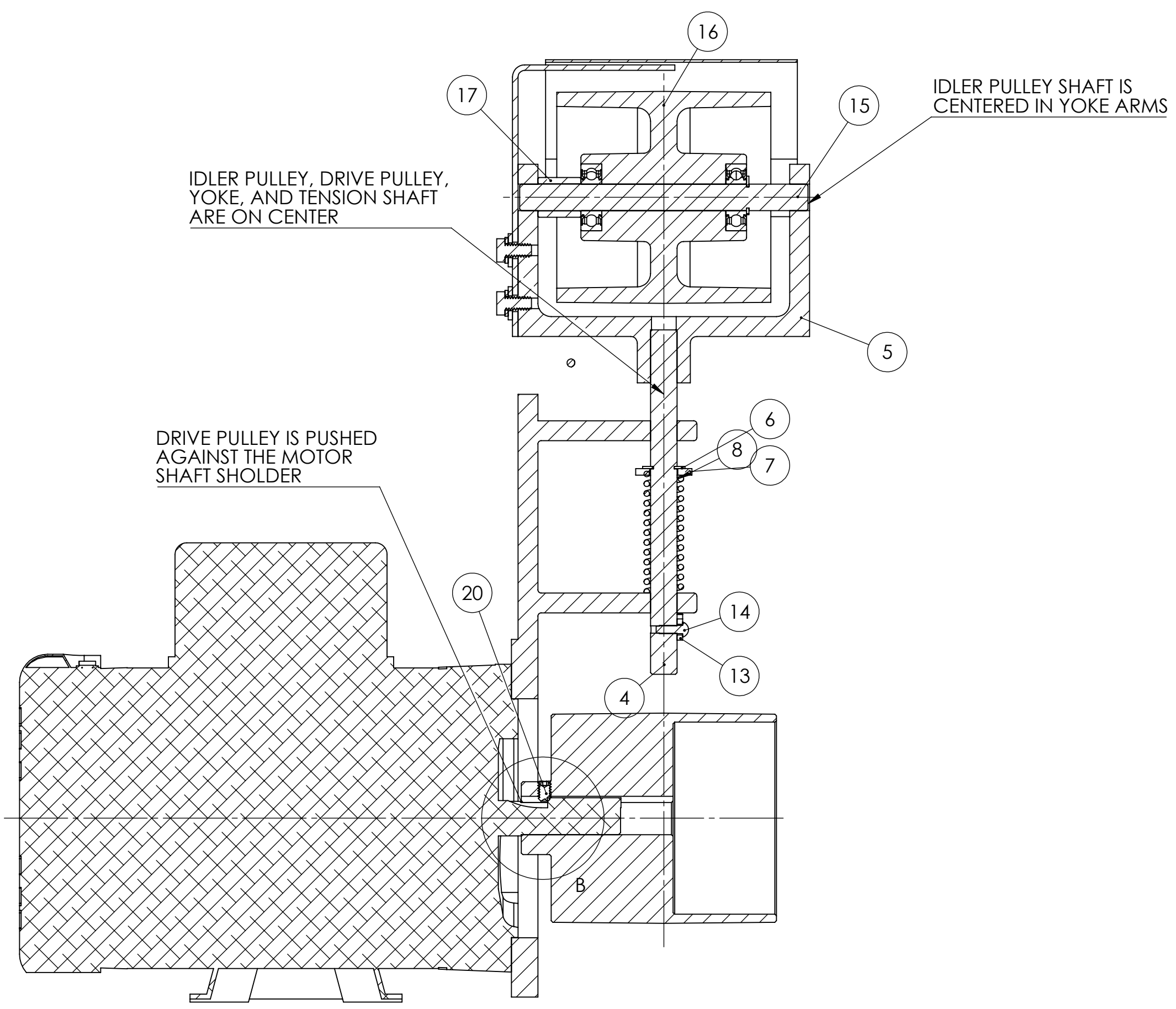

SECTION A-A

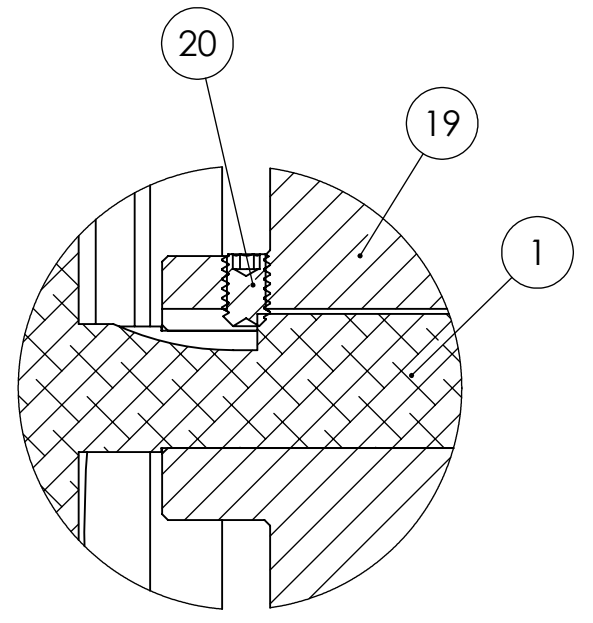

DETAIL B
DETAIL OF DRIVE PULLEY
SET SCREW

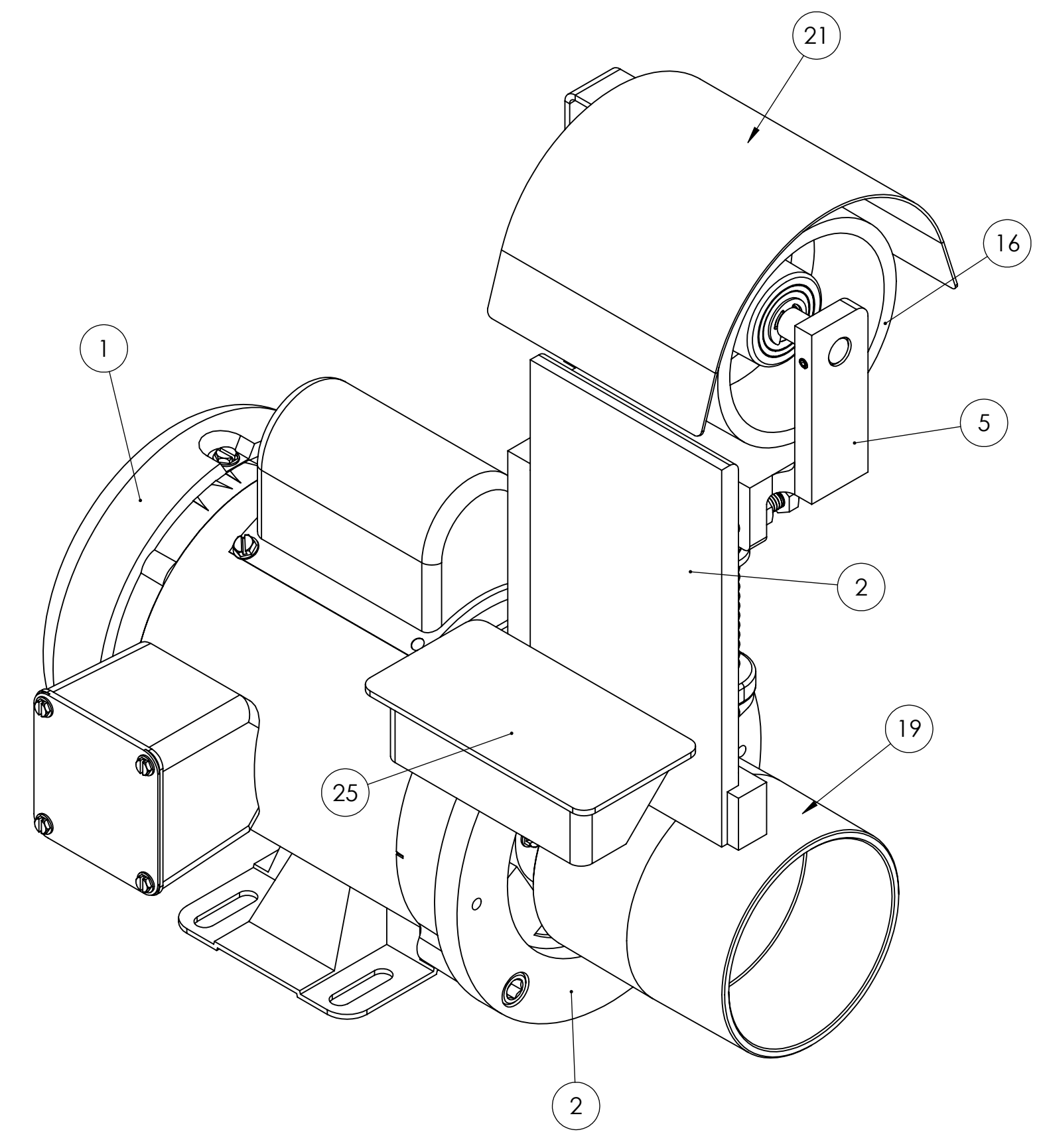

ITEM NO.	PART NUMBER	DESCRIPTION	QTY.
1	486-022	1/2HP MOTOR FOR 2FSM, S4S AND S612V VAC MOTOR	1
2	291-002	CAST IRON FRAME WITH PLATEN FOR S4, S4S, DS10-4	1
3	SHCA037012	3/8-16 X 3/4 SHCS	4
4		YOKE SHAFT FOR S4 SANDER	1
5	960-002YA	YOKE AND TENSION SHAFT ASSEMBLY	1
6	EERR0.5	EERR1/2 1/2" E RETAINING RING	2
7	UFWZ050	1/2 USS F/W Z	1
8	697-010	SPRING, TENSION FOR S4 SANDERS	1
9	HHC5031020	TRACKING SCREW	1
10	FHN5031	5/16-18 FHN GR5 ZINC	1
11	697-011	TRACKING SPRING FOR S4	1
12	CRMZ010024	10-24 X 1-1/2 COMBO ROUND M/S Z	1
13	129-008	CAM FOR S4 TENSION SHAFT	1
14	RUDZ007008	#7 X 1/2 RD U-DRIVE SCREW Z	1
15	701-008	SPINDLE, IDLER FOR S4, S460 SANDERS	1
16	560-006	IDLER PULLEY S4 W BEARINGS FOR S4S AND S460	1
17	123-003	COLLAR FOR S4	1
18	SSKA010004	10-24 X 1/4 SOC SET KNURL PT	2
19	560-005	PULLEY, DRIVE (ALUMINUM) FOR S4, S4S, S460D	1
20	SSKA025006	1/4-20 X 3/8 SOC SET KNURL PT.	1
21	342-005	GUARD, UMBRELLA FOR S4 SANDERS	1
22	HHC5025008	1/4-20 X 1/2 HHCS GR5 Z	2
23	UFWZ025	1/4 USS F/W Z	2
24	SLWZ025	1/4 SPLIT L/W Z	2
25	829-004	WORK TABLE FOR 2", 4", DS10-4 SANDERS	1
26	HHC5031012	5/16-18 X 3/4 HHCS GR5 Z	1
27	UFWZ031	5/16 USS F/W Z	1
28	SLWZ031	5/16 SPLIT L/W Z	1

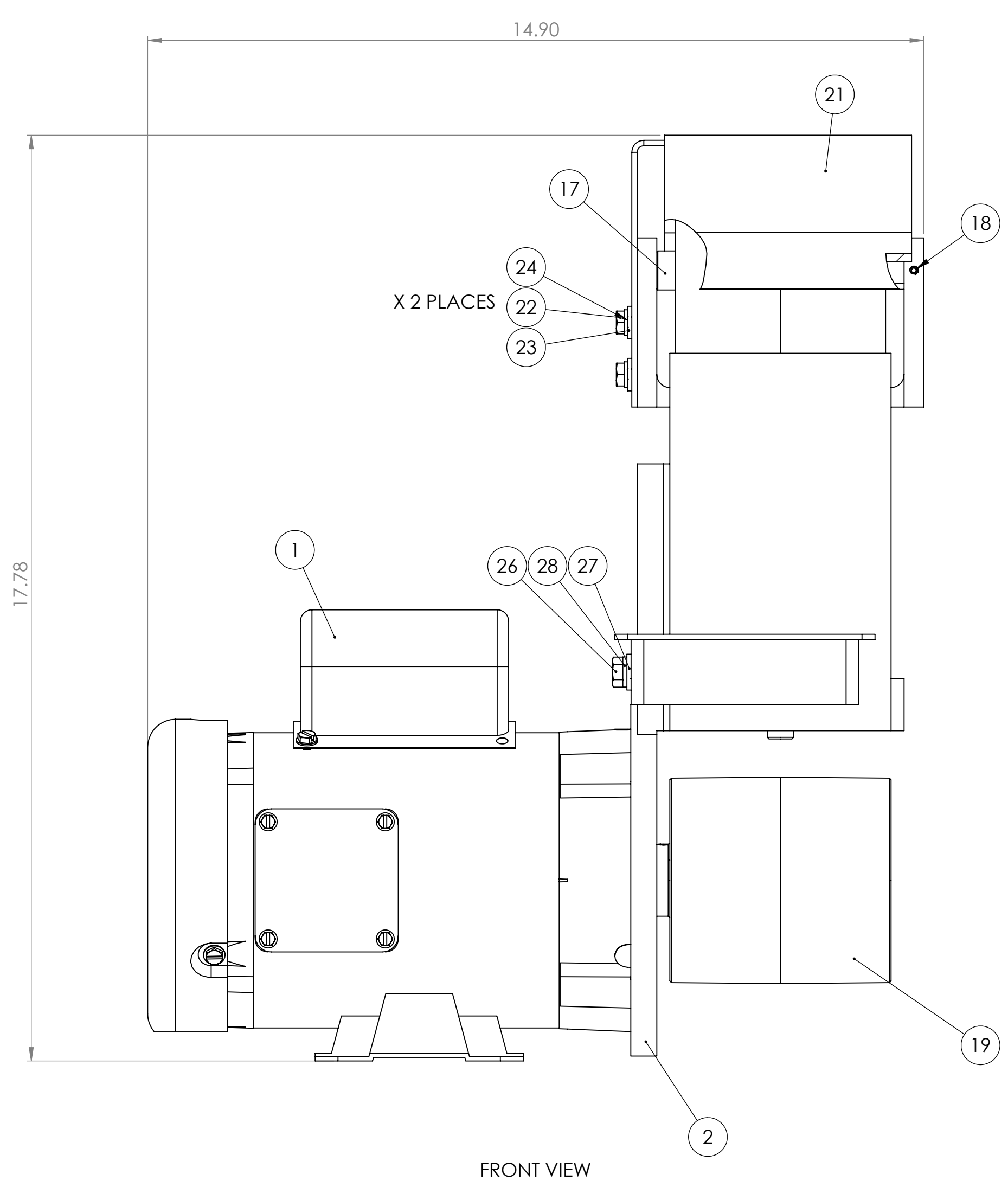

FRONT VIEW

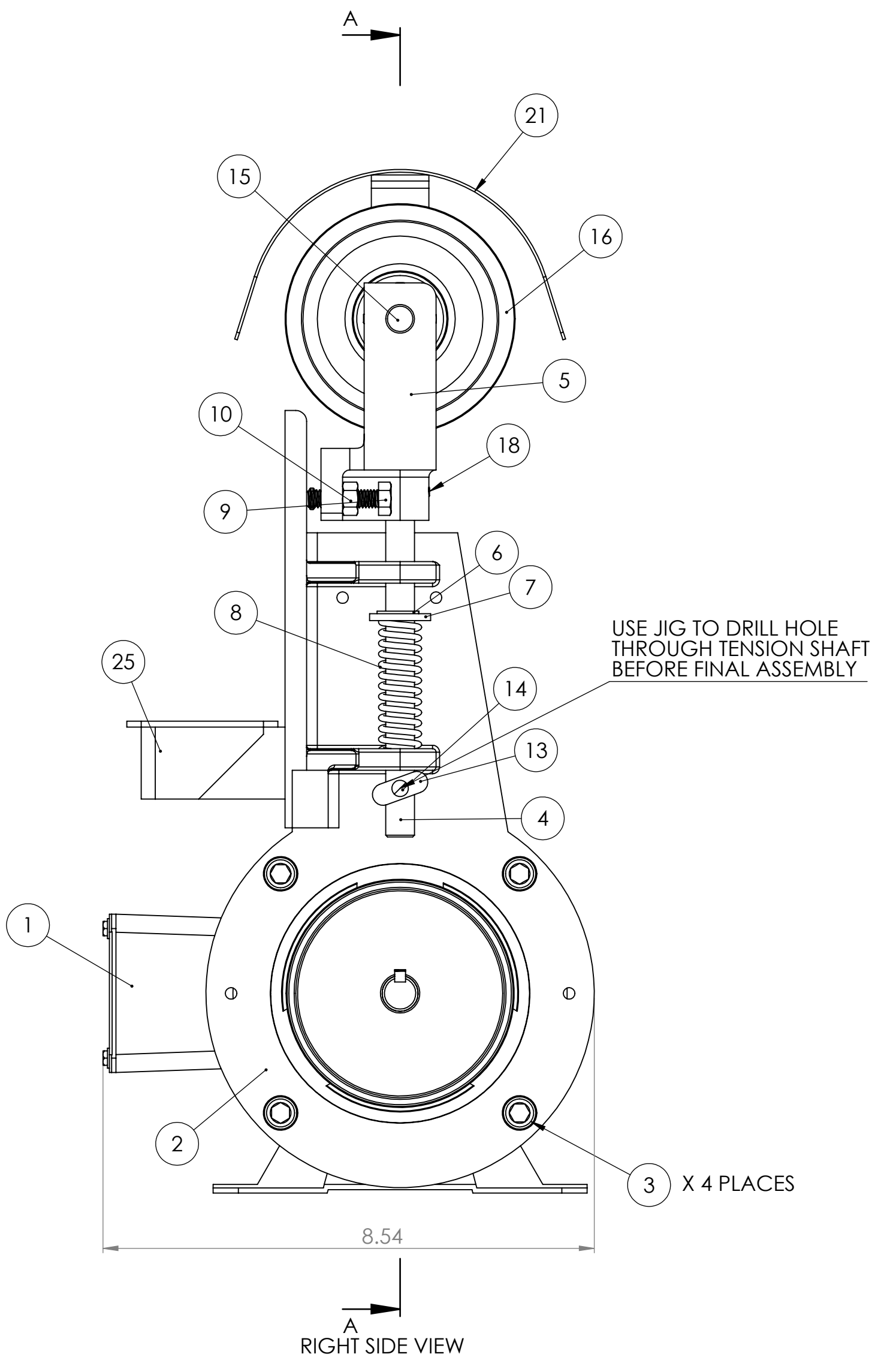

RIGHT SIDE VIEW

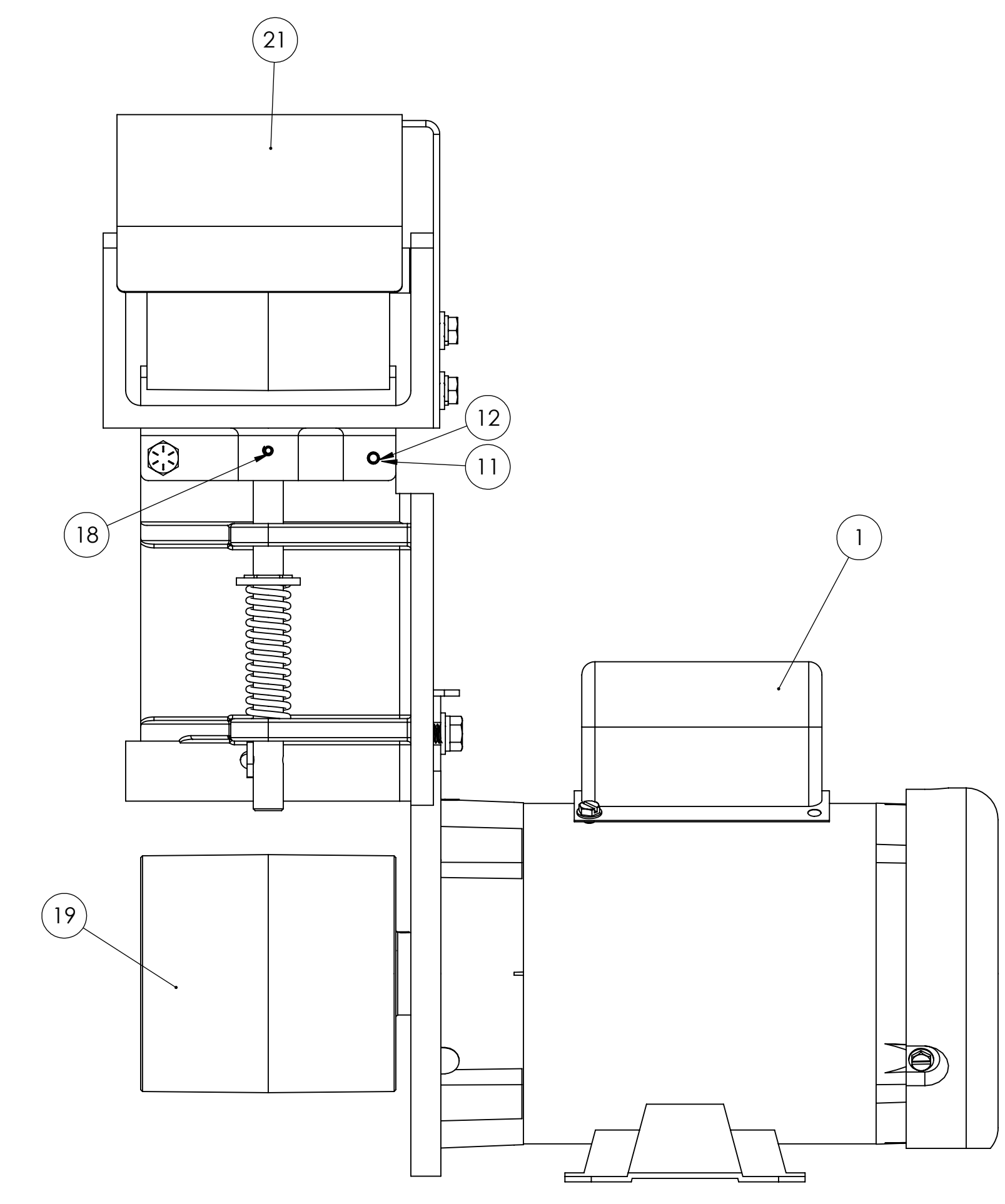

BACK VIEW

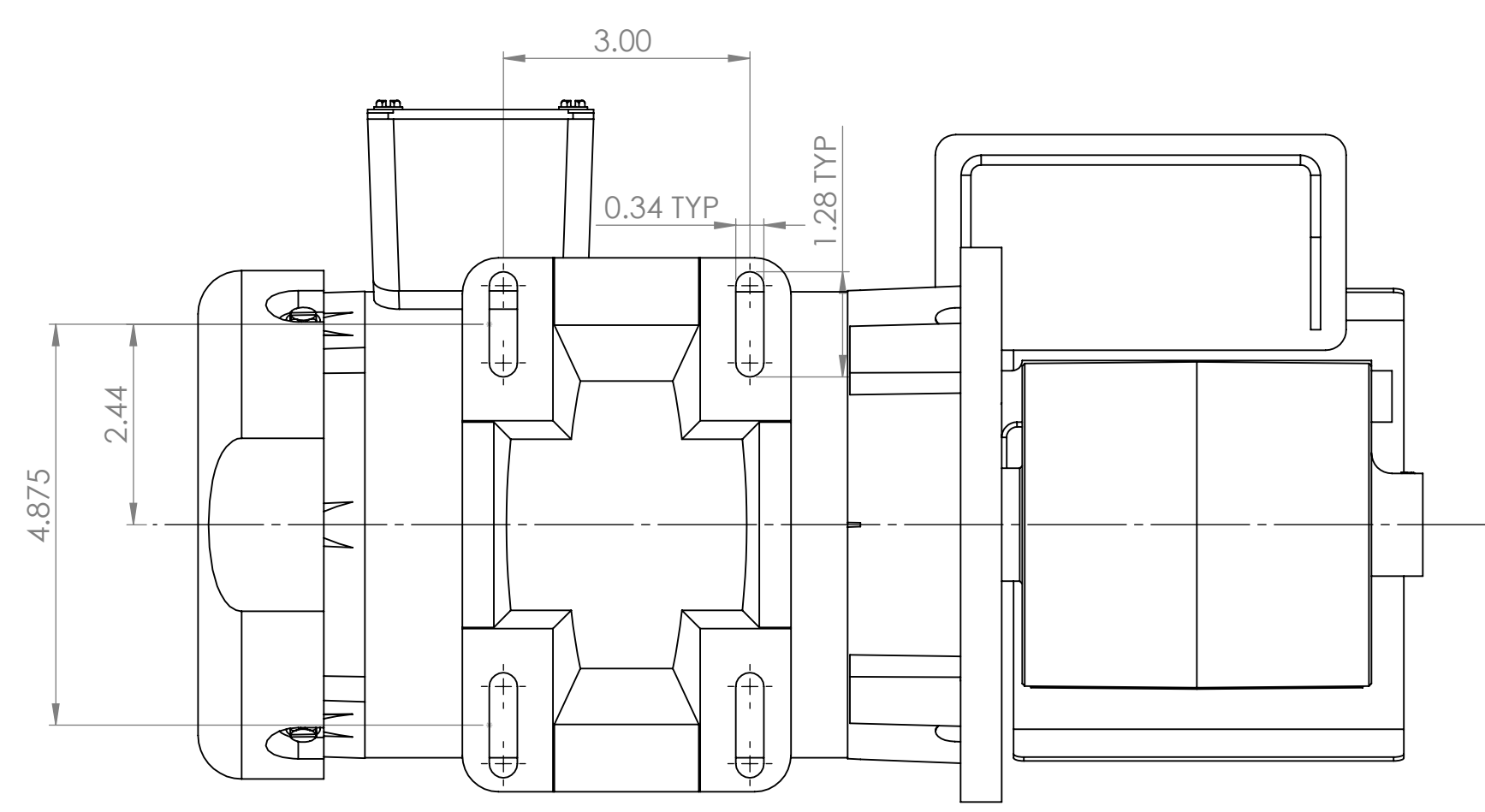

BOTTOM VIEW

PROPRIETARY AND CONFIDENTIAL
THE INFORMATION CONTAINED IN THIS DRAWING IS THE SOLE PROPERTY OF KALAMAZOO. IT IS TO BE USED ONLY FOR THE SPECIFIC PROJECT AND FOR THE CUSTOMER'S USE. ANY REPRODUCTION IN PART OR AS A WHOLE WITHOUT THE WRITTEN PERMISSION OF KALAMAZOO IS PROHIBITED.

UNLESS OTHERWISE SPECIFIED:	NAME	DATE
DIMENSIONS ARE IN INCHES	DRAWN	
TOLERANCES:	CHECKED	
FRACTIONALS	ENG APPR	
ANGULARS	ENG APPR	
PROFILES	ENG APPR	
THREE PLACE DECIMAL	ENG APPR	
INTERFERENCE GEOMETRIC TOLERANCES	D.A.	
MATERIAL	COMMENTS	
NEATNESS	USED ON	
APPLICATION	DO NOT SCALE DRAWING	

KALAMAZOO
TITLE: **S4 BELT SANDER ASSEMBLY**
SIZE: **E** DWG. NO.: **S4 BELT SANDER ASSEMBLY** REV
SCALE: 1:2 WEIGHT: SHEET 1 OF 1