

**KI** **KALAMAZOO**  
INDUSTRIES, INC.  
KALAMAZOO, MI.



PH: (269) 382-2050

[www.kalamazooind.com](http://www.kalamazooind.com)

## K12-14B 14" ABRASIVE SAW INDUSTRIAL MANUAL



**MADE IN USA**

# WARNING!

TO REDUCE THE RISK OF FIRE OR SHOCK HAZARD, DO NOT EXPOSE THIS EQUIPMENT TO RAIN, ANY LIQUID OR MOISTURE.

## INSPECTION

If these goods are damaged in transit, the **DELIVERING TRANSPORTATION COMPANY** is required by law to make notation of damages on the freight bill. If in your opinion, there may be concealed damage, they are required to make an inspection after goods are unpacked. Transportation rates are made in proportion to damage. Therefore, the carrier and **NOT** the shipper should be charged with any loss or damage. Any claim should be filed with the delivering Transportation Company. **PLEASE DO NOT RETURN GOODS TO US WITHOUT OUR RGA NUMBER AND SHIPPING INSTRUCTIONS.**

**Electrical: CAUTION:** Voltage changes require wiring changes at drive motor. **WARRANTY DOES NOT COVER** unauthorized wiring changes/failures. **Consult an electrician an electrician if your not familiar with electrics.**

### K12-14B SETUP

- BEFORE STARTING OR CONNECTING ELECTRICAL VERIFY THE PHASE AND VOLTAGE OF THE UNIT.
- BE SURE MACHINE IS BALANCED CORRECTLY SO IT WILL TIP OVER.
- TO GUARD AGAINST CONCEALED DAMAGE, STAND CLEAR AND OBSERVE UNIT FOR THE FIRST FEW MINUTES OF OPERATION. GUARDS MUST NEVER BE REMOVED.
- BEFORE INSTALLING THE ABRASIVE WHEEL CONFIRM THAT THE CUTOFF WHEEL IS DESIGNED TO RUN AT 4800 SFPM (MOS). YOU CAN FIND THIS INFORMATION DIRECTLY ON THE THE SIDE OF YOUR CUTOFF WHEEL. IT

### ABRASIVE SAW SAFETY

- NEVER REMOVE SAFETY GUARDS FROM MACHINE. DISCONNECT MACHINE FROM POWER SOURCE BEFORE MAKING ANY MACHINE ADJUSTMENTS.
- DO NOT USE AROUND FLAMMABLE MATERIALS OR LIQUIDS.
- MACHINES SHOULD BE OPERATED IN VENTILATED AREAS.
- ALWAYS WEAR SAFETY GLASSES OR A FULL FACE SHIELD FOR PROTECTION.
- DO NOT USE TOOTHED BLADE WITH THIS SAW AND DO NOT ATTEMPT TO USE STEEL BLADES ON THIS SAW.
- KEEP HANDS CLEAR OF THE CUTTING AREA.
- DO NOT WEAR GLOVES OR LOOSE FITTING CLOTHES WHEN OPERATING THIS MACHINE.
- ALWAYS KEEP HAIR TIED BACK OR COVERED.
- ALWAYS KEEP FLANGES CLEAN AND TIGHT AGAINST CUTTING WHEEL.
- MANUALLY TIGHTEN AND LOOSE SPINDLE NUT.
- DO NOT USE IMPACTED GUN TO LOOSEN OR TIGHTEN SPINDLE NUT.
- ALWAYS KEEP WHEEL GUARD IN THE DOWN POSITION.
- BE SURE WORK PIECE IS CLAMPED SECURELY IN VISE BEFORE CUTTING.

### WARNING!!!!

IMPROPER USE MAY CAUSE BREAKAGE AND SERIOUS INJURY.

#### DO

1. **DO** always handle and store wheels in the vertical position.
2. **DO** visually inspect all wheels before mounting for possible damage.
3. **DO** check machine speed against the established maximum safe operating speed marked on the wheel.
4. **DO** check mounting flanges for equal and correct diameter.
5. **DO** use mounting blotters when supplied with wheels.
6. **DO** always use a safety guard covering a least one-half of the abrasive wheel.
7. **DO** allow newly mounted wheels to run at operating speed, with guard in place, for at least one minute before cutting.
8. **DO** always wear safety glasses or some type of eye protection when cutting.
9. **DO** tie back hair.

#### DON'T

1. **DON'T** use a cracked wheel or one that has been dropped or has become damaged.
2. **DON'T** force a wheel onto the machine or alter the size of the mounting hole if wheel won't fit the machine.
3. **DON'T** ever exceed maximum operating speed established for the wheel.
4. **DON'T** use mounting flanges on which the bearing surfaces are not clean, flat and free of burrs.
5. **DON'T** tighten the spindle nut excessively.
6. **DON'T** start the machine until the wheel guard is in place.
7. **DON'T** jam work into wheel.
8. **DON'T** force cutting so that motor slows noticeable or work gets hot.
9. **DON'T** wear gloves and or have loose clothing when operating machine.
10. **DON'T** use tooth blade on saw.

## BASIC OPERATION

1. Be certain correct wiring is matched to motor.
2. Always keep flanges clean and tight against the abrasive wheel.
3. Be certain work piece is securely clamped in the vise. Any movement in the work piece during cutting will result in broken abrasive cutoff blades.
4. Keep the blade guard in the down position at all times. Guarding is designed for abrasive blades only. **DO NOT USE STEEL TOOTHED BLADES!!!**  
**GUARDING IS NOT DESIGNED FOR STEEL TOOTHED BLADES PER OSHA AND ANSI STANDARDS.**
5. Select the correct abrasive wheel for the material. Every abrasive wheel performs differently. Kalamazoo Industries #KAB14R reinforce wheels give free cutting on most mild steels. Good cuts are bright like the material and not burned or discolored. If burning occurs then select another grade of abrasive wheel. Consult your dealer or wheel manufacturer for wheel grade selection. It may take many test cuts on different wheels to obtain the wheel that work the best for your material. Use enough cutting force to make the wheel wear or “break down”.
6. **Saw spindle speed is set at 4,400 SFPM select cutoff wheel that’s designed to run at 4,400 SFPM or greater. Using cutoff wheel’s designed to run under 4,400 SPM could cause wheel failure and could cause serious injury to operator. Contact the wheel manufacturer or dealer for the correct wheel.**
7. Always follow safety procedures. Wear safety glasses, never wear gloves or loose fitting clothing that can get caught in the moving parts and tie back loose hair. Always keep hands out of swing area when cutting. See attached safety sheet.
8. V-belts will stretch with use over time. Keep v-belt tight with ½” of “squeeze”. Use a v-belt tensioner **(051-035)** to tighten v-belt belt. Keep both faces of spindle and motor pulley aligned in the same plane with a straight edge. Check motor and spindle pulleys set prior to operating the machine.

INCOMING LINE VOLTAGE  
CONNECTS TO 1L1, 3L2, AND 5L3

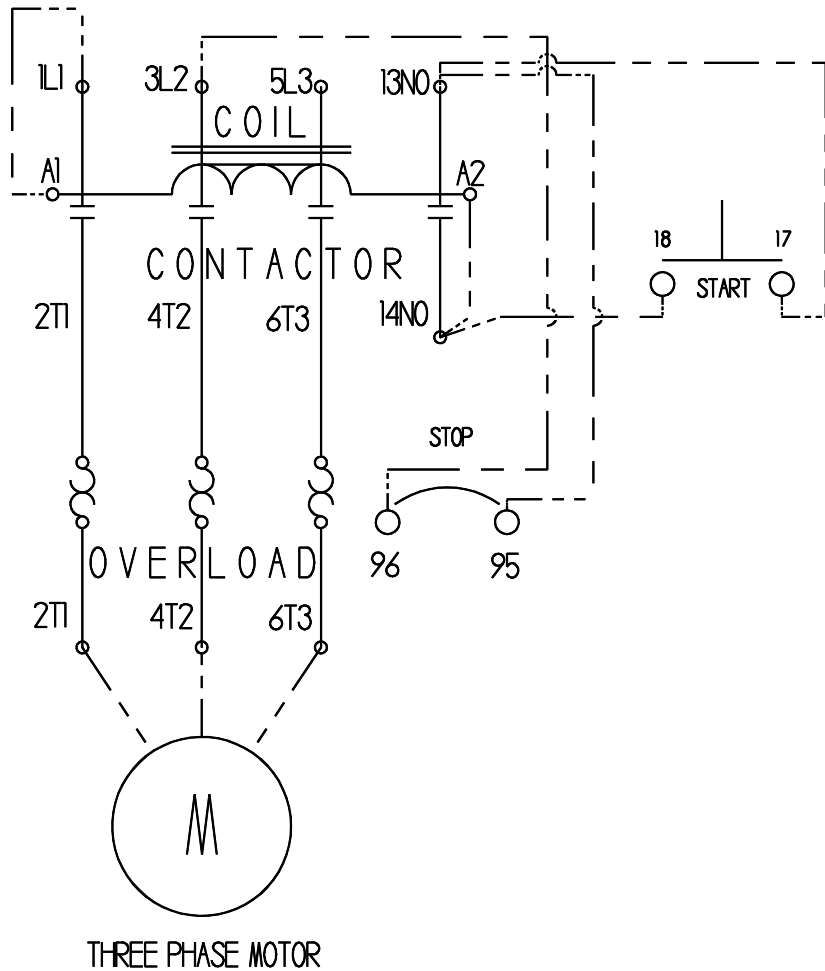

MOTOR LEAD CONNECTION

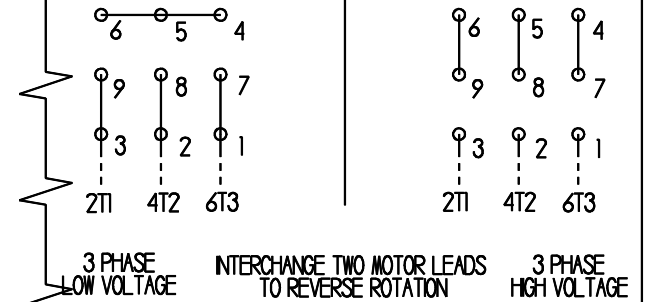

**KALAMAZOO INDUSTRIES INC.**

DRAWN BY	DATE	DESCRIPTION
ASHLEY	9/19/12	3 PH SCHEMATIC
REVISED BY	DATE	PART #
MATERIAL		

Y  
X

INCOMING LINE VOLTAGE  
CONNECTS TO 1L1 AND 3L2

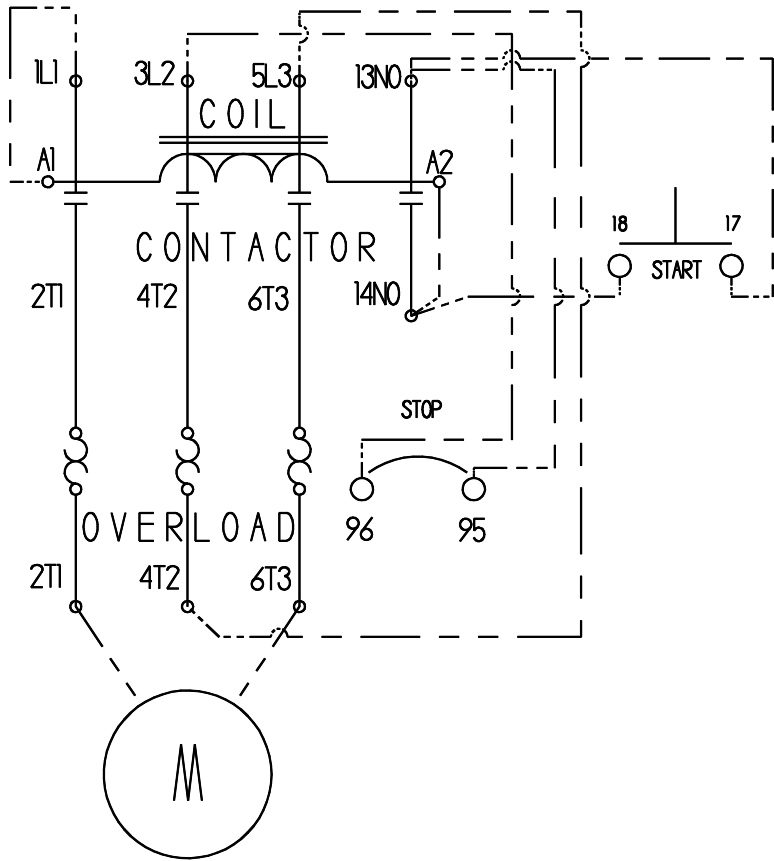

SINGLE PHASE MOTOR

MOTOR LEAD CONNECTION

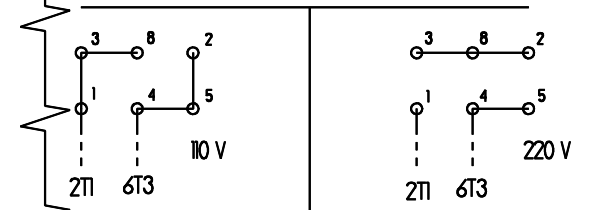

INTERCHANGE #5 AND #8 LEADS  
TO REVERSE ROTATION

### KALAMAZOO INDUSTRIES INC.

DRAWN BY	DATE	DESCRIPTION
ASHLEY	9/19/12	1 PH SCHEMATIC
REVISED BY	DATE	PART #
MATERIAL		

Y  
X

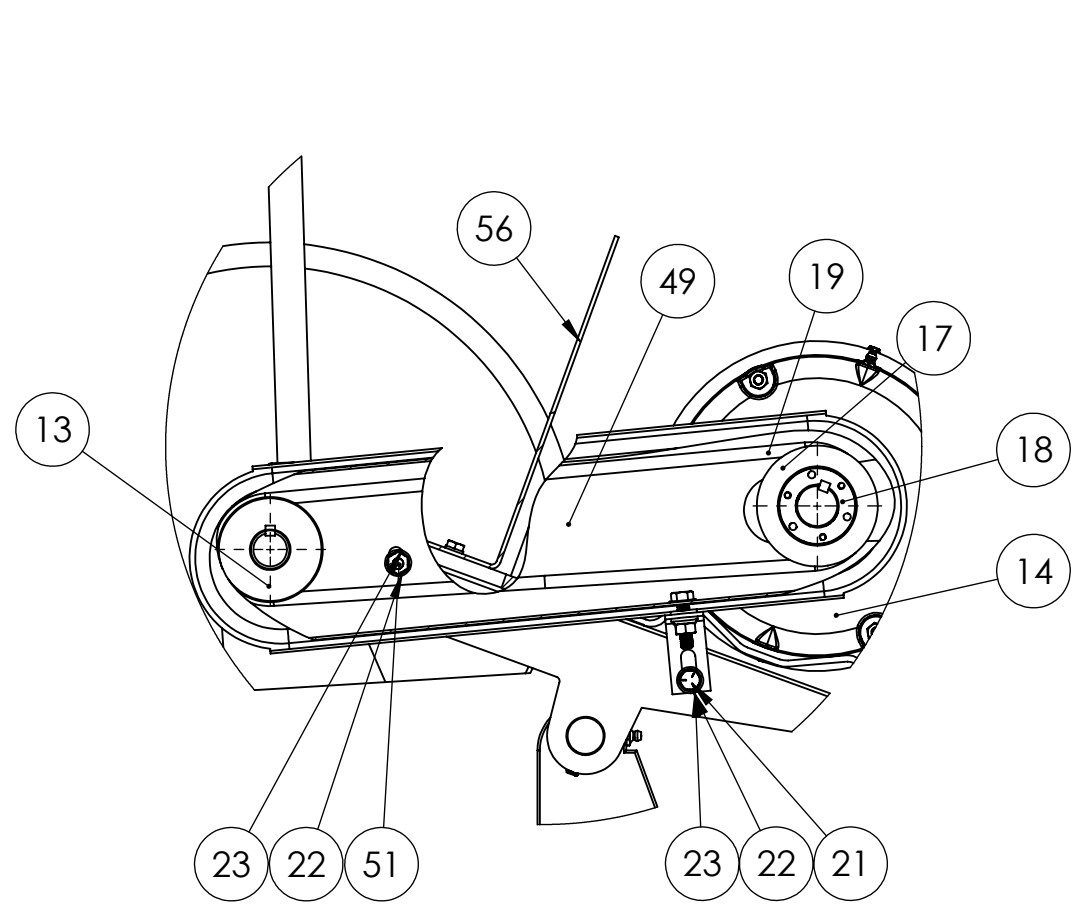

DETAIL A  
SCALE 1 : 5  
PULLEYS, BELTS,  
AND GUARD  
DETAIL

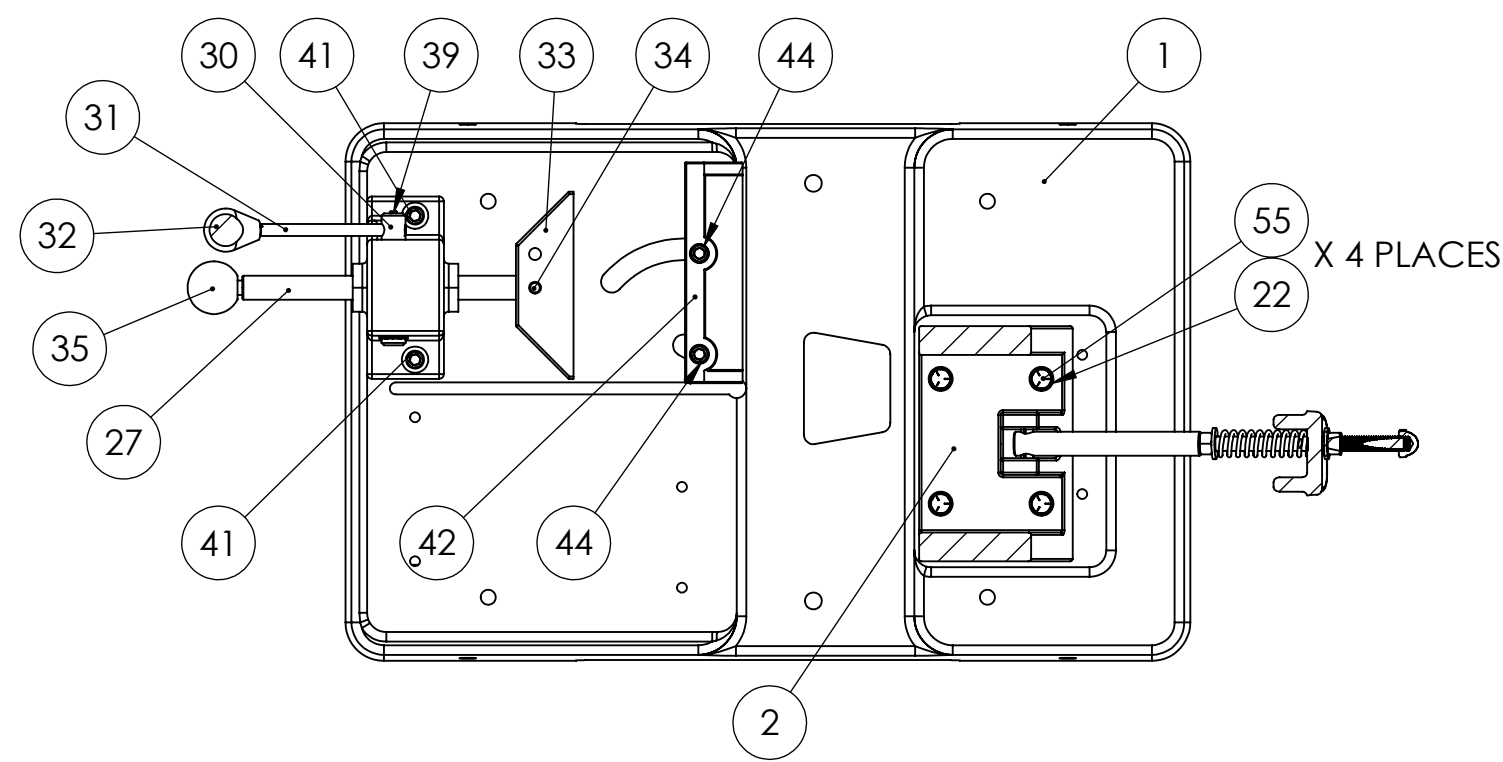

SECTION F-F  
SCALE 1 : 5  
PIVOT BLOCK AND  
VISE MOUNTING  
DETAILS

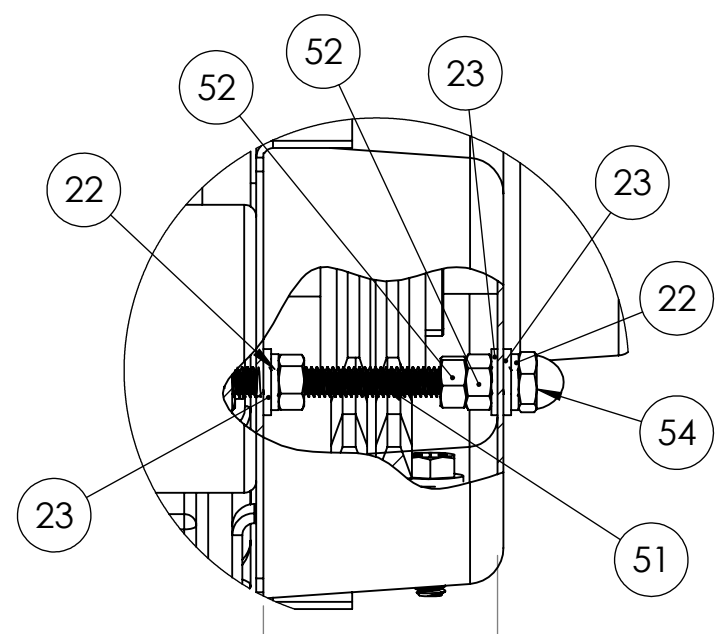

DETAIL L  
SCALE 1 : 2  
ATTACH PLASTIC  
GUARD

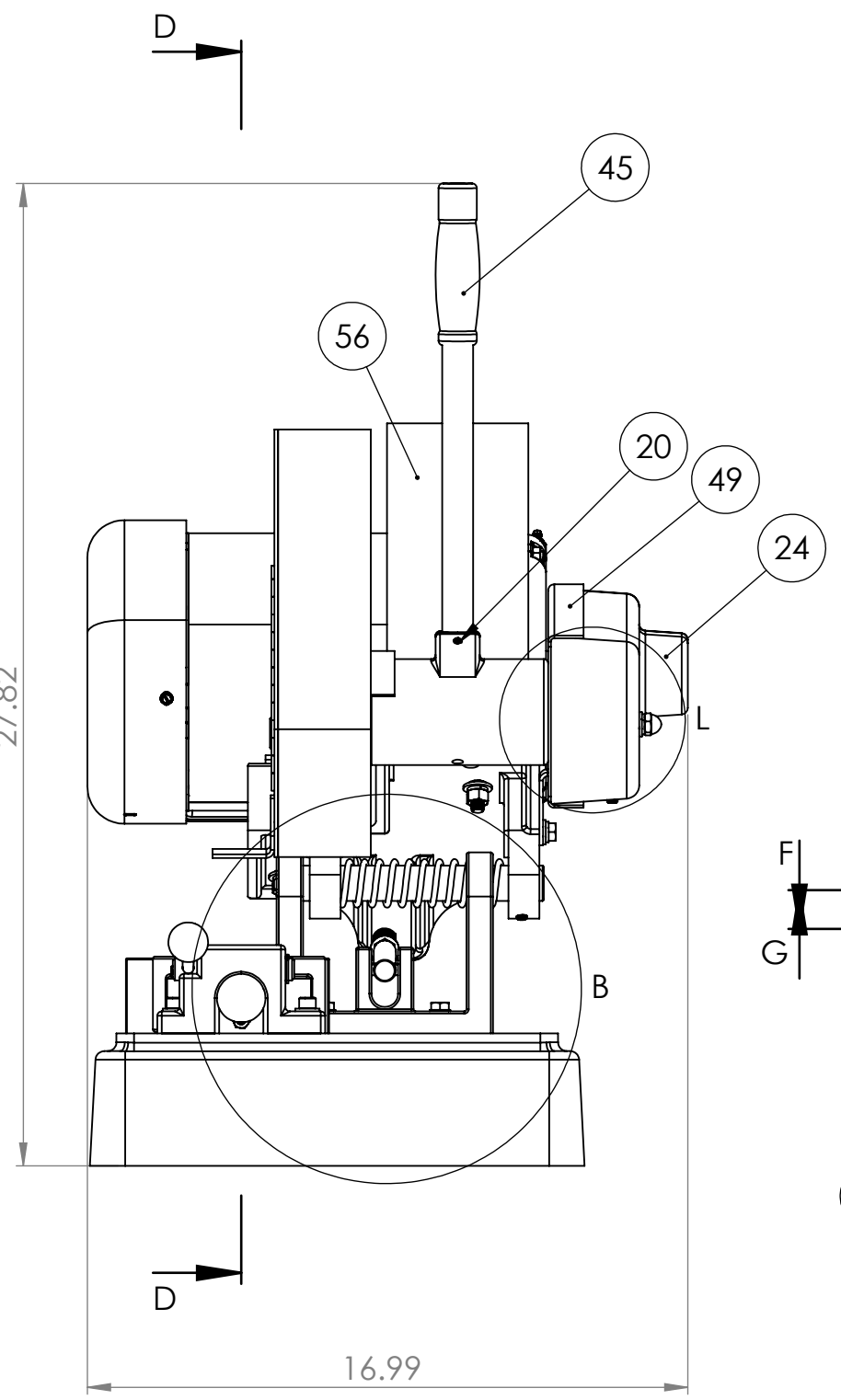

SECTION D-D  
SCALE 1 : 5  
VISE DETAIL

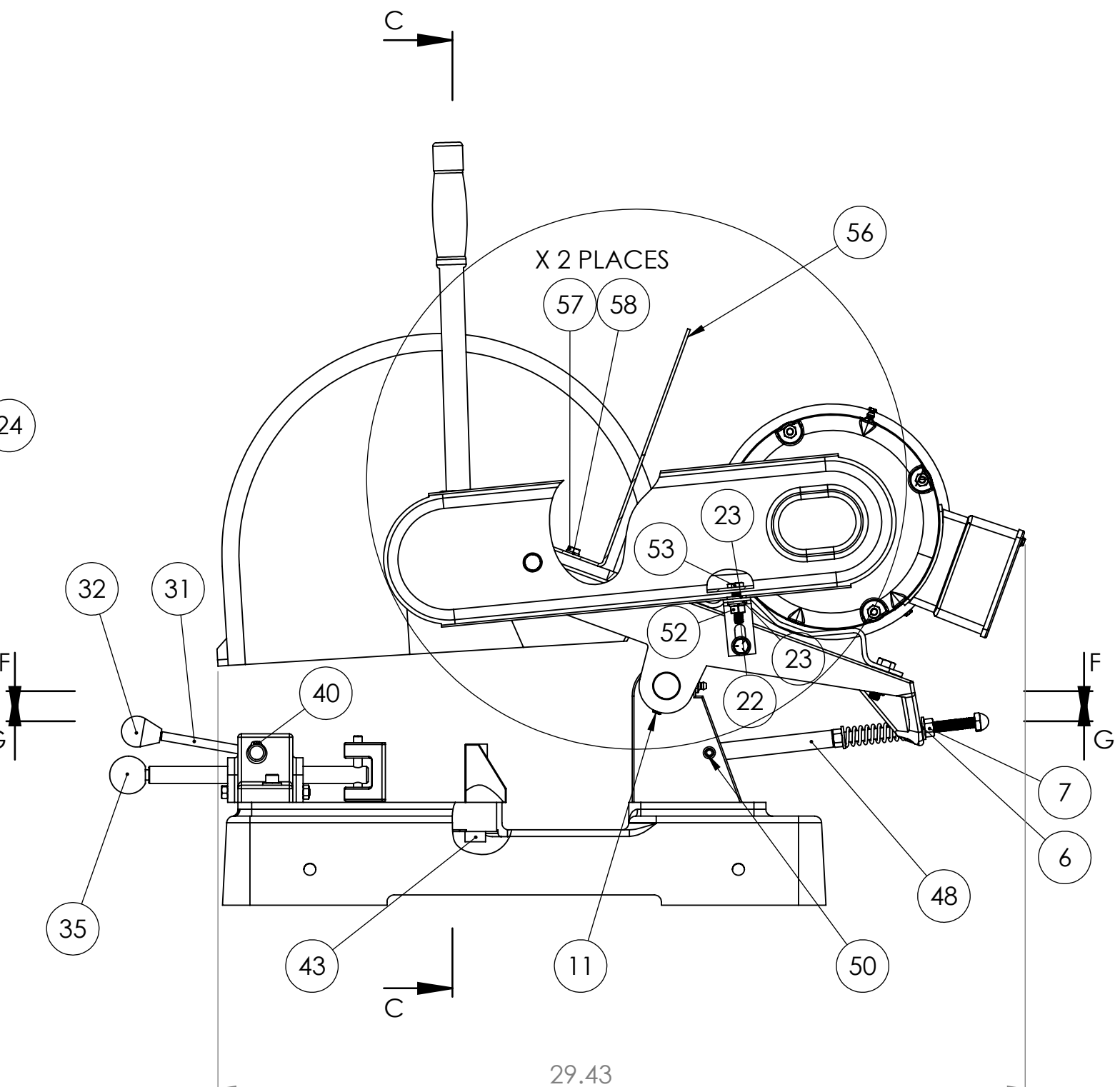

SECTION C-C  
SCALE 1 : 5

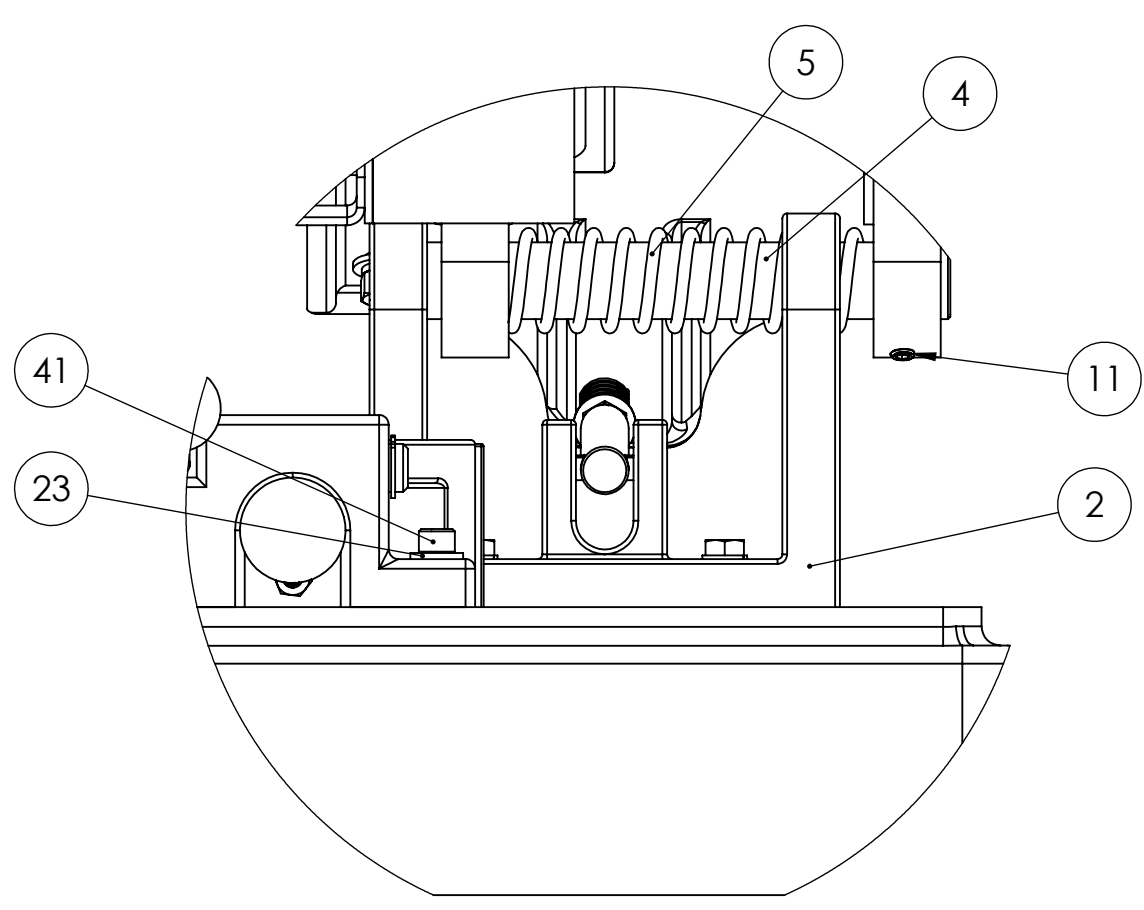

DETAIL B  
SCALE 2 : 5  
PIVOT, SPRING  
AND PIVOT SHAFT  
DETAIL

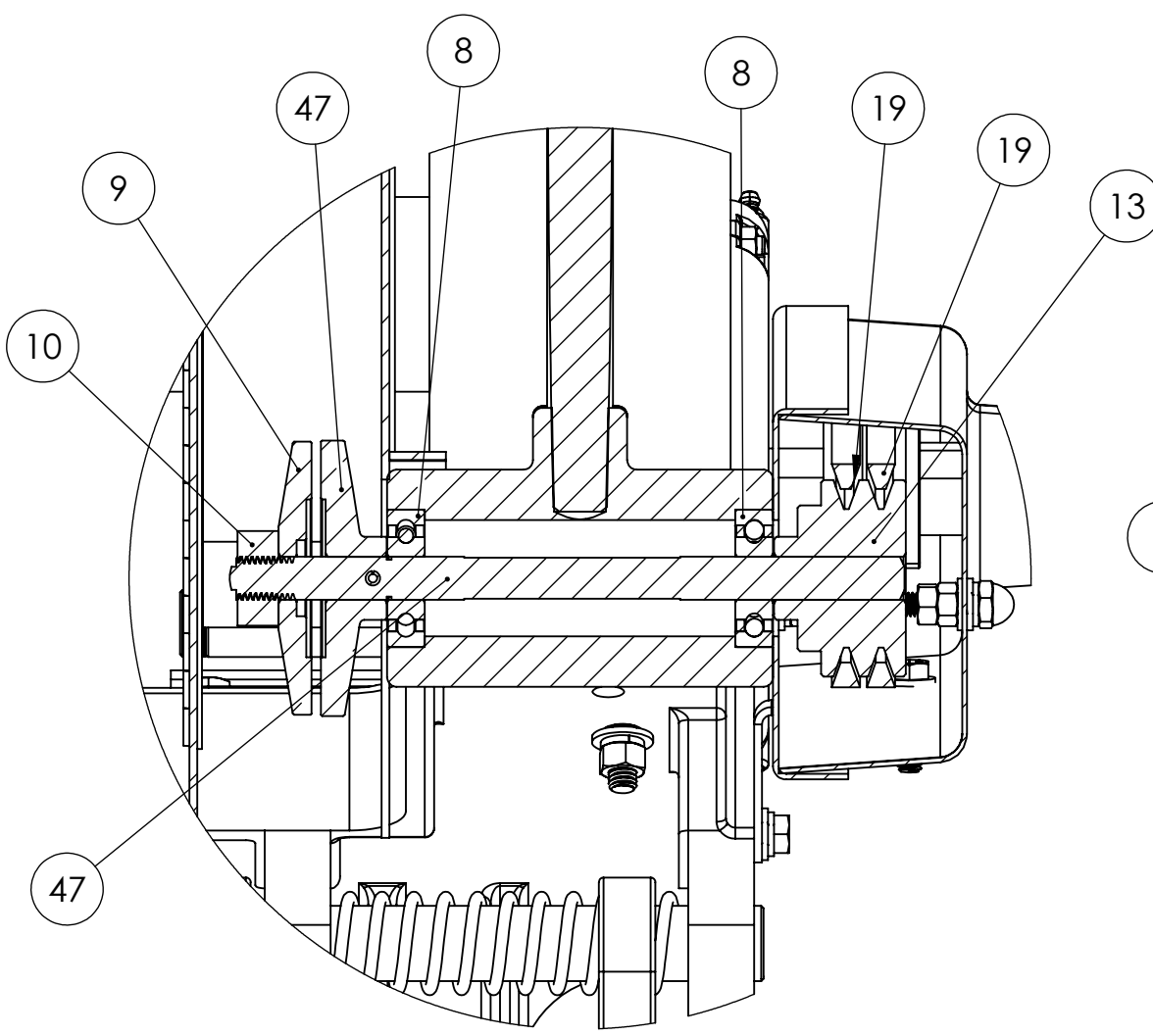

DETAIL E  
SCALE 2 : 5  
SPINDLE, PULLEY,  
BELTS,  
AND BEARINGS  
DETAIL

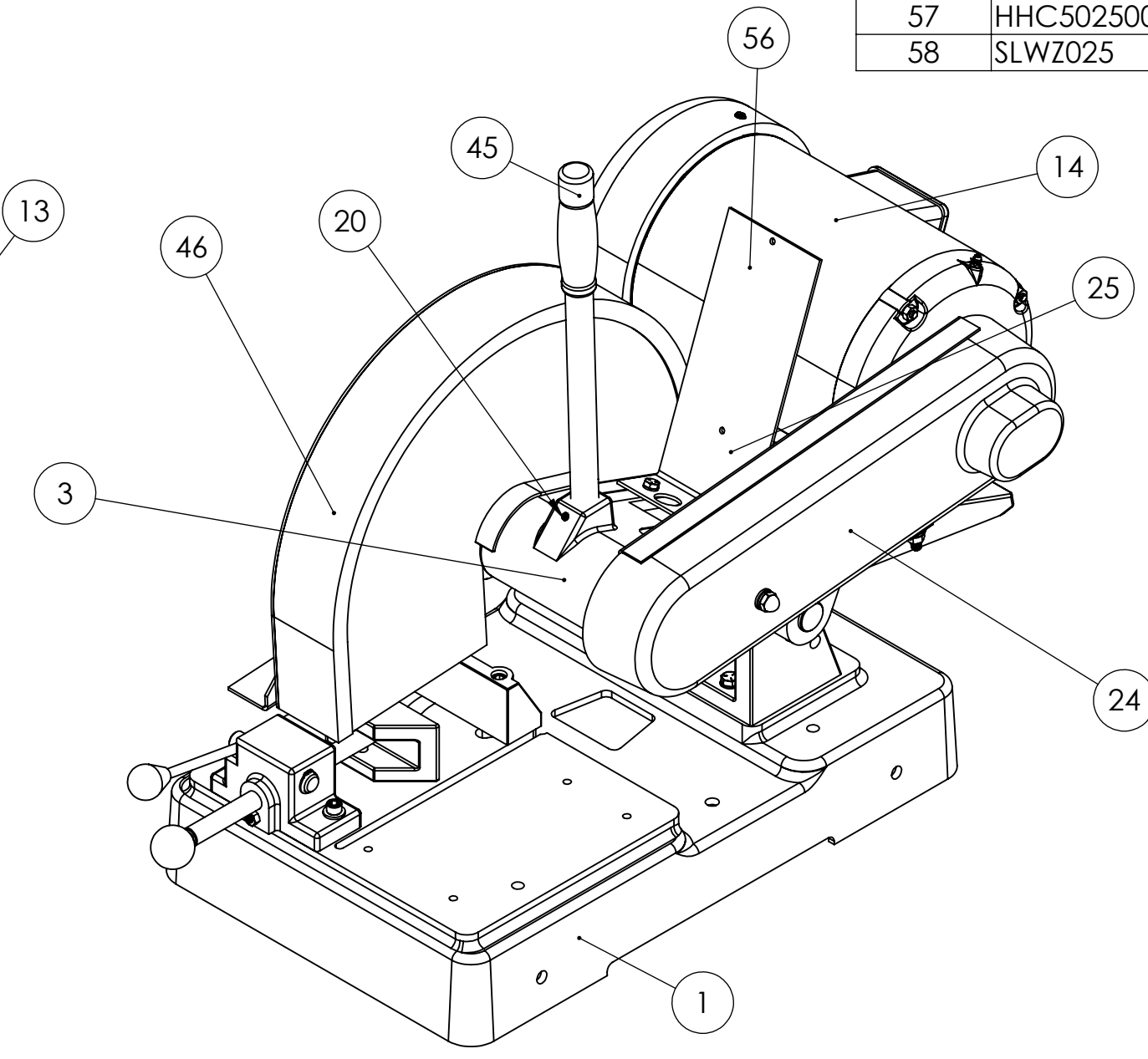

SECTION G-G  
SCALE 1 : 5  
BOTTOM SIDE OF  
MOTOR MOUNT  
DETAIL

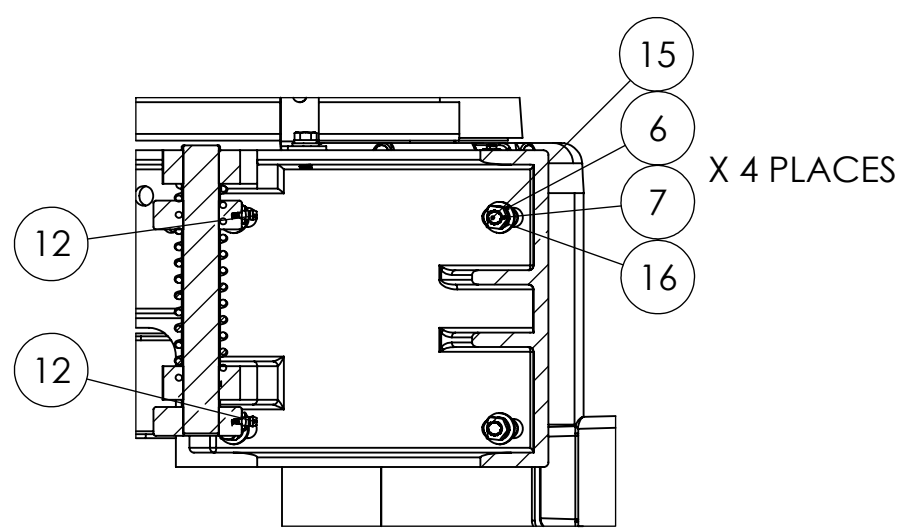

ITEM NO.	PART NUMBER	DESCRIPTION	QTY.
1	050-002	K12-14 SAW BASE	1
2	041-003	K12-K14 TRUNNION	1
3	002-002	K12- 14 SAW ARM	1
4	562-003	K12-14 TRUNNION PIN	1
5	697-024	SPRING, TENSION FOR BG260, S460, S6M SANDERS, K12-14B SAW, KS390, KS490, KS690 BELT GRINDERS	1
6	UFWZ037	3/8 USS F/W Z	5
7	FHN5037	3/8-16 FHN GR5 Z	5
8	044-001	K12 BEARING	2
9	292-004	K12-14 LOOSE FLANGE	1
10	537-026	L.H. SPINDLE NUT 1" -14 FOR K14, KM14	1
11	SSKA031006	5/16-18 X 3/8 SOC SET KNURL PT.	1
12	ZERK012000	1/8-27 X 11/16 STRT LUBE FITTING	2
13	560-001	K12- 14 SPINDLE PULLEY	1
14	486-001	5 HP MOTOR FOR K12B, K14B, KM14, KM14HS & S6MS-5HP	1
15	HHC5037020	3/8-16 X 1-1/4 HHCS GR5 Z	4
16	SLWZ037	3/8 SPLIT L/W Z	4
17	560-002	MOTOR PULLEY SHEAVE FOR K12-14B, K12-14W, K12-14MS AND KM14	1
18	049-022	MOTOR PULLEY BUSHING FOR K12B, K14B AND KM14	1
19	051-006	V-BELT (TWO REQUIRED) FOR K12, K14, KM14 SAWS (SAME AS 051-009)	2
20	SSKA025004	1/4-20 X 1/4 SOC SET KNURL PT.	3
21	HHC5031012	5/16-18 X 3/4 HHCS GR5 Z	1
22	SLWZ031	5/16 SPLIT L/W Z	8
23	UFWZ031	5/16 USS F/W Z	9
24	342-004	K12-14 OUTER BELT GUARD/PLASTIC	1
25	SSBA062044	5/8 X 2-3/4 SOC SHOULDER BOLT	1
26	386-001	K10-16 VISE HOUSING	1
27	645-001	K10-16 SHORT VISE ROD	1
28	454-001	K10-16 VISE CAM PLATE	1
29	697-001	K10-16 VISE ROD SPRING	1
30	129-001	K10-16 VISE CAM	1
31	381-001	K10- 16 VISE HANDLE	1
32	441-002	K10-16 VISE LOCK HANDLE KNOB	1
33	431-001	FRONT VISE JAW K10, K14, KM14	1
34	562-001	VISE JAW PIN FOR K10B, K12B, K14B, KM16-18 VISE ASSEMBLIES	1
35	441-001	K10- 16 VISE ROD KNOB	1
36	SSSA025024	1/4-20 X 1-1/2 SOC SET CUP PT.	1
37	SSSA025022	1/4-20 X 1-3/8 SOC SET CUP PT.	1
38	FHN5025	1/4-20 FHN GR5 Z	2
39	SSKA010004	10-24 X 1/4 SOC SET KNURL PT	1
40	641-016	RETAINING RING FOR S6, S460W, S612	1
41	SHCA031024	5/16-18 X 1-1/2 SHCS	2
42	431-002	K10- 14 REAR VISE JAW	1
43	537-014	K10-14 FENCE NUT	1
44	SHCA031048	5/16-18 X 3 SHCS	2
45	381-002	HANDLE W GRIP FOR K12-14 SAWS	1
46	342-025	WHEEL GUARD FOR K12-14B SAWS	1
47	701-002	SPINDLE W TIGHT FLANGE FOR K12B, K14B, K12-14W, KM14, K12-14MS	1
48	645-004	K12B- 14B BACK STOP ASSEMBLY	1
49	342-086	K12-14 INNER BELT GUARD ASSEMBLY FOR PLASTIC GUARD	1
50	ROLA031024	5/16 X 1-1/2 ROLL PIN	1
51	RND-5/16-18THRDX3.75	3-3/4 INCHES OF 5/16-18 THREADED ROD	1
52	FHN5031	5/16-18 FHN GR5 ZINC	4
53	HHC5031020	5/16-18 X 1-1/4 HHCS GR 5 Z	1
54	CPNZ031	5/16-18 CAP NUT NICKEL	1
55	HHC5031024	5/16-18 X 1-1/2 HHCS GR5 Z	4
56	041-057	SWITCH BRACKET FOR K12-K14	1
57	HHC5025008	1/4-20 X 1/2 HHCS GR5 Z	2
58	SLWZ025	1/4 SPLIT L/W Z	2

FOR A COMPLETE SPINDLE ASSEMBLY  
ORDER #702-004

- INCLUDES:
- 044-001 BEARINGS, QTY 2
  - 537-026 L.H. SPINDLE NUT, QTY 1
  - 701-002 SPINDLE W TIGHT FLANGE, QTY 1
  - 292-004 LOOSE FLANGE, QTY 1
  - ROLA018022, 3/16 X 1-3/8 ROLL PIN, QTY 1

PROPRIETARY AND CONFIDENTIAL  
THE INFORMATION CONTAINED IN THIS  
DRAWING IS THE SOLE PROPERTY OF  
KALAMAZOO INDUSTRIES, INC. ANY  
REPRODUCTION IN PART OR AS A WHOLE  
WITHOUT THE WRITTEN PERMISSION OF  
KALAMAZOO INDUSTRIES, INC. IS  
PROHIBITED.

UNLESS OTHERWISE SPECIFIED:	DRAWN	NAME	DATE	
DIMENSIONS ARE IN INCHES	CHECKED			
TOLERANCES:	ENG APPR.			
FRACTIONAL ±	MEG APPR.			
ANGULAR ±	Q.A.			
BEND ±	COMMENTS:			
TWO PLACE DECIMAL ±				
THREE PLACE DECIMAL ±				
INTERPRET GEOMETRIC TOLERANCING PER:				
MATERIAL				
FINISH				
APPLICATION	DO NOT SCALE DRAWING			

SIZE DWG. NO. REV  
**D** K12B-K14B MODEL ASSEMBLY  
 SCALE: 1:10 WEIGHT: SHEET 1 OF 1