

AO5C 5C COLLET FIXTURE

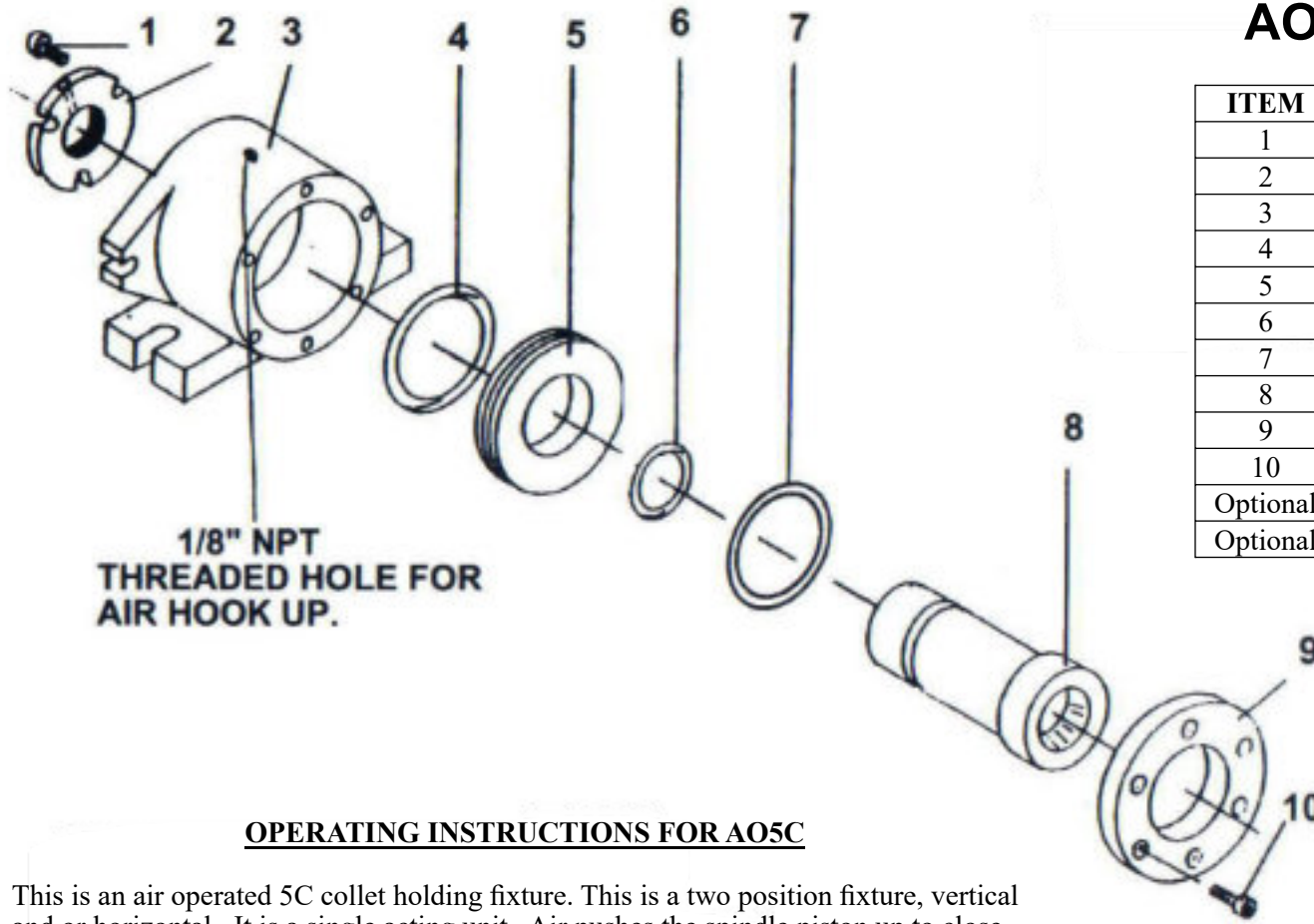

ITEM	PART NO.	DESCRIPTION
1		10-24x5/8 HHCS
2	123-001	THREADED RING
3	060-003	FIXTURE BODY
4	568-342	LARGE O-RING
5	573-001	PISTON W/SLEEVE
6	568-222	SMALL O-RING
7	697-002	NEOPRENE SPRING TUBE
8	-	SLEEVE
9	136-001	CAP
10	-	8-32x1/4 SHCS
Optional	125V	3-WAY VALVE FOR AO5C
Optional	AR-62	FOOT VALVE

OPERATING INSTRUCTIONS FOR AO5C

This is an air operated 5C collet holding fixture. This is a two position fixture, vertical and or horizontal. It is a single acting unit. Air pushes the spindle piston up to close the collet and the neoprene ring to force the piston back when the air is off.

How to use

Screw collet into the spindle unit the work to be held just turns. Then turn the air valve on, which pushes the spindle up and locks the work. Turning the air supply off will release the work

Note: This unit is not recommended for heavy milling.

Requirement

0 - 100 PSI shop air is required. Holding pressure is 5 times the line pressure.

Maintenance

Occasionally disassemble the fixture and give it a thoroughly cleaning.

**KI KALAMAZOO
INDUSTRIES, INC.**

6856 E K AVENUE
KALAMAZOO, MI 49048
(269) 382-2050 PHONE
(269) 382-0790 FAX
www.kalamazooind.com

KI KALAMAZOO INDUSTRIES, INC.

6856 E K AVENUE
KALAMAZOO, MI 49048
(269) 382-2050 PHONE
(269) 382-0790 FAX
www.kalamazooind.com

5C COLLET FIXTURES

- 1CC 5C COLLET CHUCK
- A1 UNIVERSAL-INDEXER
- RT INDEX TABLE
- RTBA INDEX TABLE WITH 6" 3 JAW CHUCK
- RTBB INDEX TABLE WITH 6' 6 JAW CHUCK
- 10C COLLET HOLDING FIXTURE
- AO5C AIR OPERATED 5C COLLET HOLDER

WHAT WE MANUFACTURING

- ABRASIVE SAWS
- BELT SANDERS
- DISC SANDERS
- LATHE CHUCKS
- INDEX FIXTURES
- DUST COLLECTORS
- VIBRATORY FINISHERS
- SEMI CUSTOM EQUIPMENT

Have a sawing, sanding and or grinding application that you need help with? Give us a call (269) 382-2050 with you application.